

Conlift1, Conlift2, Conlift2 pH+



Small lifting stations
50 Hz



1. Product overview	3
Conlift for condensate applications	3
Applications	4
Functions	4
2. Conlift1	5
Applications	5
Features	5
Sizing guide	5
Construction features	6
Installation requirements	7
Product numbers	7
Level control	7
Construction	7
Accessories	7
Technical data	8
3. Conlift2	9
Applications	9
Features	9
Sizing guide	9
Construction features	10
Installation requirements	11
Product numbers	11
Level control	11
Construction	11
Accessories	11
Technical data	12
4. Conlift2 pH+	13
Applications	13
Features	13
Sizing guide	13
Construction features	14
Installation requirements	15
Product numbers	15
Level control	15
Construction	15
Accessories	15
Technical data	16
5. Further product documentation	17
WebCAPS	17
WinCAPS	18

1. Product overview

Conlift for condensate applications

Conlift1	Features
 <p data-bbox="440 745 459 869">TM05 1810 3611</p>	<ul style="list-style-type: none"> • Four inlets with grommets to seal and fix the inlet hose. • 180 °-rotatable flange for selection of optimum discharge position. • IP24 cover for protection against splashing water. • Two snap-fasteners enabling easy access to the tank in case of service. • Pump operation test button. • Stepped outlet socket for Ø8 and Ø10 mm hoses. • Non-return valve with bayonet connection for easy service. • Special inlet design preventing sedimentation and evaporation from boiler. • Stainless-steel motor shaft additionally protected by a shaft seal. • Self-venting hydraulics. • Rotating lip seal protecting bearing and motor against evaporation from tank. • Special float switch designed to prevent evaporation from tank and corrosion on micro switches. • Alignment wheel enabling easy adjustment in wall-hung installations. • Suitable for wall-hung and floor-standing installation.
Conlift2	Features
 <p data-bbox="440 1115 459 1238">TM05 1810 3611</p>	<ul style="list-style-type: none"> • The Conlift2 has the same features as Conlift1, but incorporates a printed-circuit board (PCB) with acoustic alarm device enabling additional functions when the level in the tank reaches the high-water level. The Conlift2 can be set to start the pump and/or switch off the condensate source.
Conlift2 pH+	Features
 <p data-bbox="440 1525 459 1648">TM05 1811 3611</p>	<ul style="list-style-type: none"> • The Conlift2 pH+ has the same features as Conlift2, but is supplied with a neutralisation unit which can be installed on top of or next to the lifting station. The unit neutralises condensate with a pH value below 2.5 coming from gas or oil boilers.

Applications

Grundfos Conlift1, Conlift2 and Conlift2 pH+ are suitable for the pumping of condensate which is collected below sewer level or which cannot flow to the sewage system or drain of the building by means of a natural downward slope.

Typical applications:

- Condensate boilers. A 200 kW boiler can be drained up to 5 m duty point.
- For condensate with a pH value above 2.5.
- For condensate from air-conditioning systems, cooling and refrigeration systems, air dehumidifiers and evaporators.
- For condensate with a pH value below 2.5, use Conlift2 pH+.



TM05 1812 3611

Fig. 1 Examples of application

Functions

The condensate runs by natural fall through a hose into the tank.

The liquid level in the tank is controlled automatically by a float switch. The condensate is pumped through the discharge hose to the drain.

The Conlift has a safety overflow switch with a 1.7-metre electric cable. This overflow switch can be connected to the condensate boiler and set to stop the boiler in case of an alarm.

The Conlift has a maintenance-free shaded-pole motor with the following features:

- through-going stainless-steel shaft for pump hydraulics
- built-in thermal switch
- for intermittent operation S3.

The thermal switch stops the motor in case of overload. When the motor has cooled to normal temperature, it will restart automatically.



TM05 1813 3611

Fig. 2 Example of Conlift installation

In order to protect the sewage system, we recommend the use of a neutralisation unit. The neutralisation unit is included in Conlift2 pH+ and is available as an accessory for Conlift1 and Conlift2.

Irrespective of the capability of the Conlift, local regulations may require the installation of a neutralisation unit, even for pH values of 2.5 or higher.

2. Conlift1



TM05 1810 3611

Fig. 3 Conlift1

Applications

The Conlift1 is suitable for the pumping of condensate which is collected below sewer level or which cannot flow to the sewage system or drain of the building by means of a natural downward slope.

Typical applications:

- Condensate boilers. A 200 kW boiler can be drained up to 5 m duty point.
- For condensate with a pH value above 2.5.
- For condensate from air-conditioning systems, cooling and refrigeration systems, air dehumidifiers and evaporators.
- For condensate with a pH value below 2.5, use Conlift2 pH+.



TM05 1814 3611

Fig. 4 Example of application

Features

- Fully sealed against moisture and evaporation.
- Quick and easy installation.
- Very silent and smooth operation.
- Can be mounted on the floor or on a wall.
- Pre-assembled non-return valve.
- Pump operation test button.
- Incorporates high-water float switch.
- Fully automatic operation.
- Inlet and discharge hose connectors included.

Sizing guide

Vertical or horizontal pumping

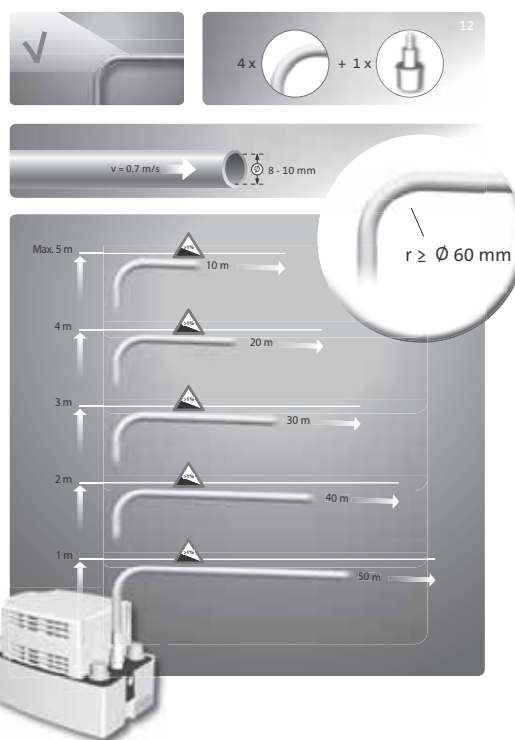

TM05 1815 3611

Fig. 5 Maximum lengths of vertical and horizontal discharge hoses

Figure 5 shows the maximum lengths of vertical and horizontal discharge hoses. The hose length depends on the hose diameter and is based on a flow velocity of 0.7 m/s. Four bends, a non-return valve and an isolating valve have already been taken into account.

Construction features

Conlift1

Description

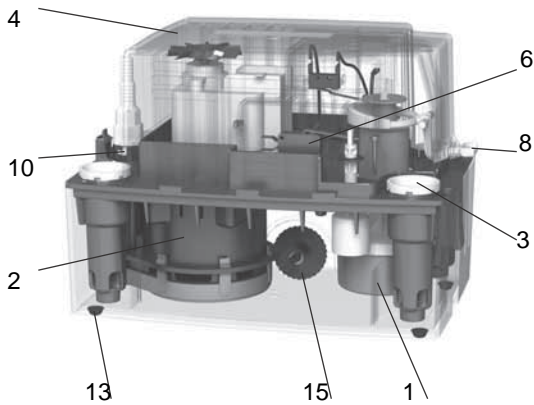

TM05 1822 4011

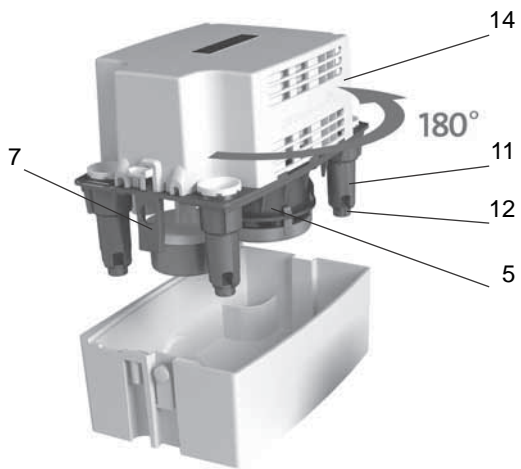

TM05 1824 4011

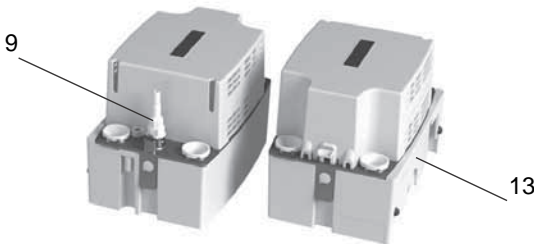

TM05 1823 4011

Pos. Operational reliability

- | | |
|---|--|
| 1 | Special float switch designed to prevent evaporation from tank and corrosion on micro switches. |
| 2 | Motor
Stainless-steel motor shaft additionally protected by a shaft seal. Rotating lip seal protecting bearing and motor against evaporation from tank.
Built-in motor protection. |
| 3 | Four inlets with grommets to seal and fix the inlet hose. |
| 4 | IP24 cover for protection against splashing water. |
| 5 | Self-venting hydraulics. |
| 6 | Overflow switch that can be connected to the condensate boiler and set to stop the boiler in case of an alarm. |

Pos. Easy maintenance and service

- | | |
|----|---|
| 7 | Two snap-fasteners enabling easy access to the tank in case of service. |
| 8 | Pump operation test button. |
| 9 | Stepped outlet socket for Ø8 and Ø10 mm hoses. |
| 10 | Non-return valve with bayonet connection for easy service. |
| 11 | Special inlet design preventing sedimentation and evaporation from boiler. |
| 12 | Four feet below inlets keeping the sensitive float system load-free in case of service. |

Pos. Easy installation and replacement

- | | |
|----|--|
| 13 | Suitable for wall-hung and floor-standing installation. |
| 14 | 180 °-rotatable flange for selection of optimum discharge position. |
| 15 | Alignment wheel enabling easy adjustment in wall-hung installations. |

Installation requirements

This section shows an installation example and describes the installation requirements. Installation is done quickly and easily by using flexible hose connectors with several adapter options for almost any hose diameter.

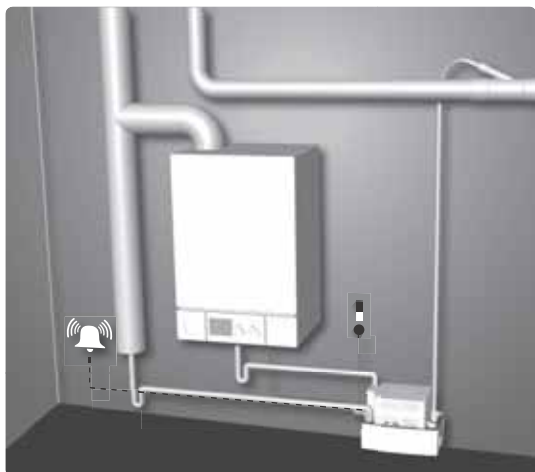

TM05 1814 3611

Fig. 6 Installation example

Connections

Four inlets with grommets to seal and fix the inlet hose. Stepped outlet socket for $\varnothing 8$ and $\varnothing 10$ mm hoses.

Product numbers

Product	Schuko plug	Without plug
Conlift1	97936156	97936173

Accessories

Accessory/ service part	Description	Product number
pH+ Box	Complete neutralisation unit including fitting accessories, neutralisation granulate and pH indicator.	97936176
Extension hose	6 metres of PVC hose with 10 mm internal diameter including one hose coupling.	97936177
Granulate refill package	Granulate, 4 x 1.4 kg and pH indicator	97936178
Alarm PCB Conlift	Printed-circuit board (PCB) enabling additional pump start at alarm level or stop of boiler with acoustic alarm.	97936209

Level control

The liquid level in the tank is controlled automatically by a float switch.

The Conlift1 can be retrofitted with an alarm PCB and a neutralisation unit which are available as accessory.

Construction

Sturdy collection tank with four inlets for wall-hung or floor-standing installation. Built-in pump with automatic level control, self-venting hydraulics and free-flow impeller for safe pumping of aggressive condensate with low solid content. The motor, float switch and pump housing are mounted on a service-friendly component bracket on top of the tank.

The additional alarm cable can either be connected to an external alarm system or to a low-voltage circuit for shutdown of condensate source.

Component	Material
Collecting tank	PP
Component bracket and cover	PP
Pump housing	PP
Impeller	PP
Shaft	Stainless steel
Discharge hose	PVC

Included fittings

- 1 inlet adapter, $\varnothing 19/32/30$ mm
- 4 inlet grommets, $\varnothing 18-22$ mm
- 1 drain pipe adapter, $\varnothing 21.5/40$ mm
- screws and plugs for wall-hung installation
- 6 metres of PVC hose, $\varnothing 10/14$ mm
- 1 alignment wheel.

Technical data

Supply voltage

1 x 230 VAC - 6 %/+ 6 %, 50 Hz, PE.
See nameplate.

Input power

P1 = 70 W.

Input current

I = 0.65 A.

Alarm connection

An external alarm can be connected via the high-water level switch.

The cable can stand a control voltage of 250 VAC, 2.5 A.

Cable length

Alarm and power supply cables: 1.7 metres.

Storage temperature

When stored in dry rooms:

- Empty tank: -10 °C to +50 °C.
- Tank with condensate: above 0 °C (risk of frost not allowed).

Ambient temperature

+5 °C to +35 °C.

Liquid temperature

- Average temperature: +50 °C.
- Briefly: maximum +90 °C for 5 minutes.

Operating mode

Intermittent operation:

S3 - 30 %, 1 minute, 60 starts/hour.

Maximum head

5.5 metres.

Maximum flow rate

600 litres/hour.

pH value of condensate

2.5 or higher.

Density of condensate

Maximum 1000 kg/m³.

Motor protection

- Thermal overload switch: +120 °C.
- Insulation class: F.

Enclosure class

IP24.

Weight

2.0 kg.

Volume

- Tank volume: 2.65 litres.
- Useful volume: 0.9 litre.
- Alarm condition: 2.1 litres.
- Operating condition: 1.7 litres.

Dimensions

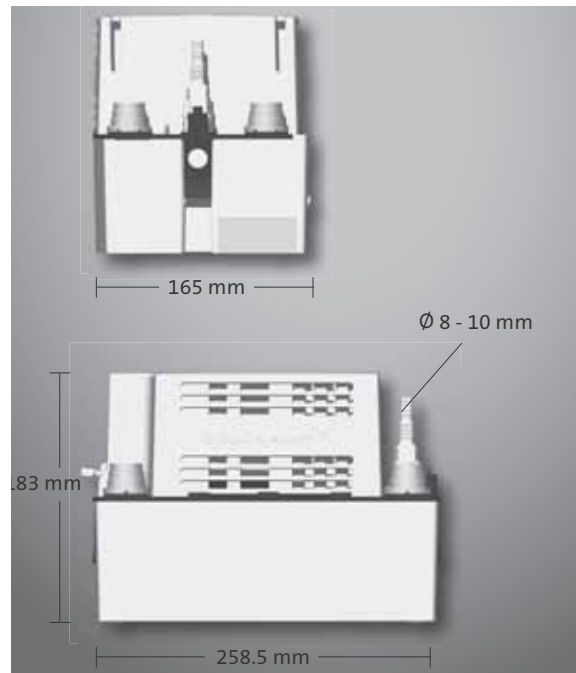

Fig. 7 Dimensions

TM05 1816 3611

Performance

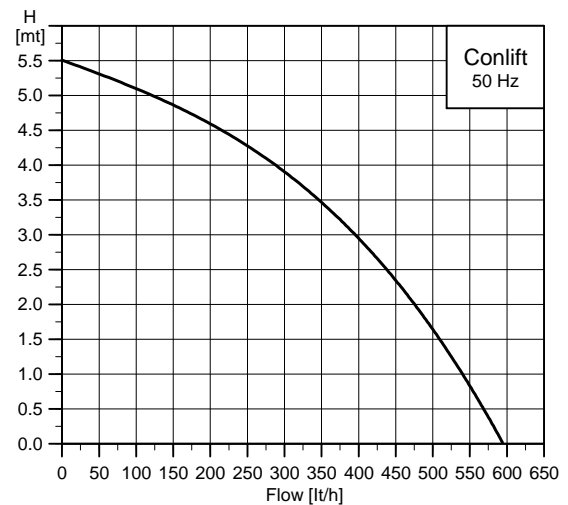

Fig. 8 Performance curve

TM05 1868 3811

3. Conlift2



TM05 1810 3611

Fig. 9 Conlift2

Applications

The Conlift2 is designed for a higher safety level than Conlift1. It comes with an integrated alarm device offering acoustic alarm when the high-water level is reached and the possibility of switching the boiler source off or starting the pump to keep the boiler running until service can be performed.

Typical applications:

- Condensate boilers. A 200 kW boiler can be drained up to 5 m duty point.
- For condensate with a pH value above 2.5.
- For condensate from air-conditioning systems, cooling and refrigeration systems, air dehumidifiers and evaporators.
- For condensate with a pH value below 2.5, use Conlift2 pH+.

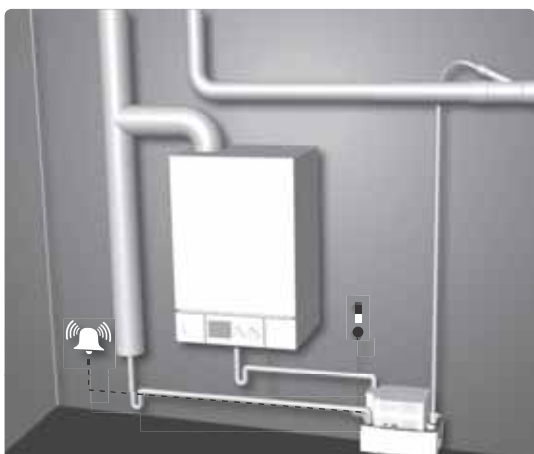

Fig. 10 Example of application

TM05 1814 3611

Features

- Fully sealed against moisture and evaporation.
- Quick and easy installation.
- Very silent and smooth operation.
- Can be mounted on the floor or on a wall.
- Pre-assembled non-return valve.
- Pump operation test button.
- Incorporates high-water float switch.
- Acoustic high-water alarm device offering the possibility of starting the pump and/or switching the boiler source off.
- Detects kinked discharge hose.
- Fully automatic operation.
- Inlet and discharge hose connectors included.

Sizing guide

Vertical or horizontal pumping

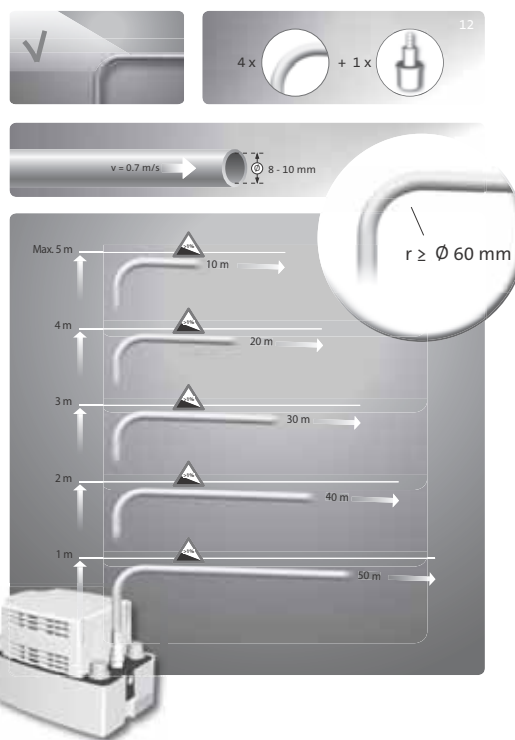

TM05 1815 3611

Fig. 11 Maximum lengths of vertical and horizontal discharge hoses

Figure 11 shows the maximum lengths of vertical and horizontal discharge hoses. The hose length depends on the hose diameter and is based on a flow velocity of 0.7 m/s. Four bends, a non-return valve and an isolating valve have already been taken into account.

Construction features

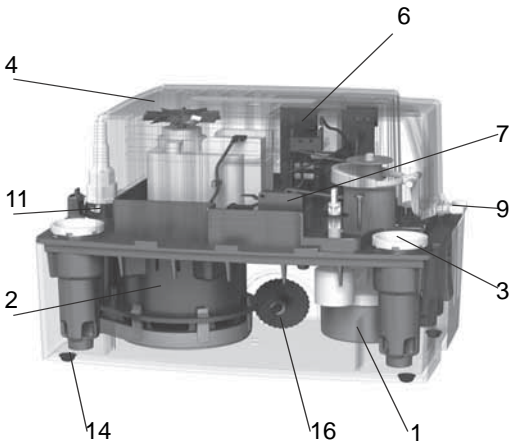
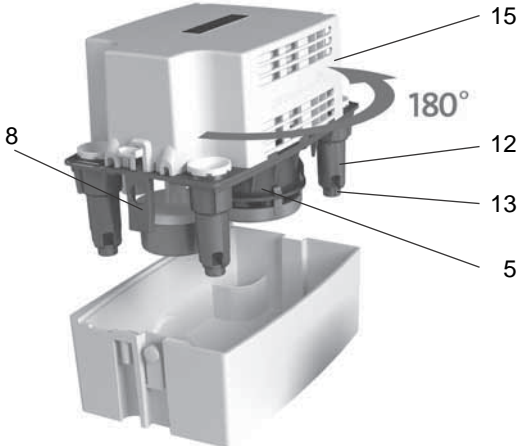
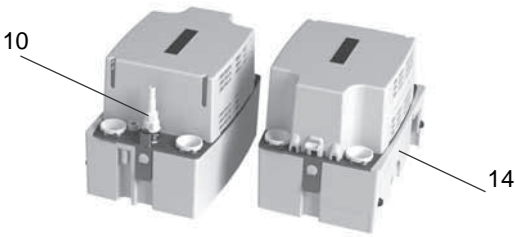
Conlift2	Description
	Pos. Operational reliability
	1 Special float switch designed to prevent evaporation from tank and corrosion on micro switches.
	2 Motor Stainless-steel motor shaft additionally protected by a shaft seal. Rotating lip seal protecting bearing and motor against evaporation from tank. Built-in motor protection.
	3 Four inlets with grommets to seal and fix the inlet hose.
	4 IP24 cover for protection against splashing water.
	5 Self-venting hydraulics.
	6 Printed-circuit board (PCB) with acoustic alarm device enabling additional pump start.
	7 Overflow switch that can be connected to the condensate boiler and set to stop the boiler in case of an alarm.
	Pos. Easy maintenance and service
	8 Two snap-fasteners enabling easy access to the tank in case of service.
	9 Pump operation test button.
	10 Stepped outlet socket for Ø8 and Ø10 mm hoses.
	11 Non-return valve with bayonet connection for easy service.
	12 Special inlet design preventing sedimentation and evaporation from boiler.
13 Four feet below inlets keeping the sensitive float system load-free in case of service.	
	Pos. Easy installation and replacement
	14 Suitable for wall-hung and floor-standing installation.
	15 180 °-rotatable flange for selection of optimum discharge position.
16 Alignment wheel enabling easy adjustment in wall-hung installations.	

TM05 1825 4111

TM05 1824 4111

TM05 1823 4011

Installation requirements

This section shows an installation example and describes the installation requirements. Installation is done quickly and easily by using flexible hose connectors with several adapter options for almost any hose diameter.

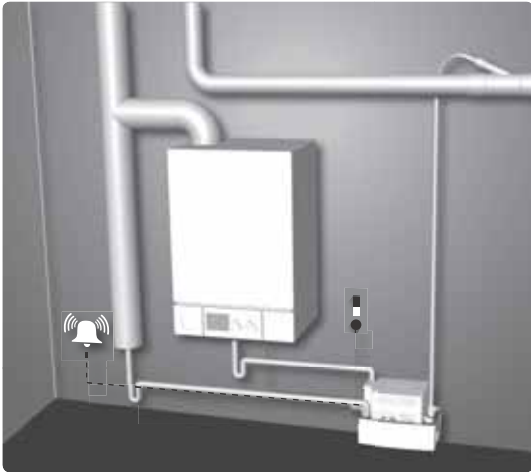

TM05 1814 3611

Fig. 12 Installation example

Connections

Four inlets with grommets to seal and fix the inlet hose. Stepped outlet socket for $\varnothing 8$ and $\varnothing 10$ mm hoses.

Product numbers

Product	Schuko plug	Without plug
Conlift2	97936158	97936174

Level control

The liquid level in the tank is controlled automatically by a float switch.

Conlift2 incorporates a printed-circuit board (PCB) enabling additional functions when the level in the tank reaches high-water level.

The contact on the PCB can be set to two positions:

Position 1: The pump is started and an acoustic alarm is generated.

Position 0: The condensate source is switched off and an acoustic alarm is generated.

The Conlift2 can be retrofitted with a neutralisation unit which is available as an accessory.

Construction

Sturdy collection tank with four inlets for wall-hung or floor-standing installation. Built-in pump with automatic level control, self-venting hydraulics and free-flow impeller for safe pumping of aggressive condensate with low solid content. The motor, float switch and pump housing are mounted on a service-friendly component bracket on top of the tank.

The additional alarm cable can either be connected to an external alarm system or to a low-voltage circuit for shutdown of condensate source.

Component	Material
Collecting tank	PP
Component bracket and cover	PP
Pump housing	PP
Impeller	PP
Shaft	Stainless steel
Discharge hose	PVC

Included fittings

- 1 inlet adapter, $\varnothing 19/32/30$ mm
- 4 inlet grommets, $\varnothing 18-22$ mm
- 1 drain pipe adapter, $\varnothing 21.5/40$ mm
- screws and plugs for wall-hung installation
- 6 metres of PVC hose, $\varnothing 10/14$ mm
- 1 alignment wheel.

Accessories

Accessory/ service part	Description	Product number
pH+ Box	Complete neutralisation unit including fitting accessories, neutralisation granulate and pH indicator.	97936176
Extension hose	6 metres of PVC hose with 10 mm internal diameter including one hose coupling.	97936177
Granulate refill package	Granulate, 4 x 1.4 kg and pH indicator	97936178
Alarm PCB Conlift	Printed-circuit board (PCB) enabling additional pump start at alarm level or stop of boiler with acoustic alarm.	97936209

Technical data

Supply voltage

1 x 230 VAC - 6 %/+ 6 %, 50 Hz, PE.
See nameplate.

Input power

P1 = 70 W.

Input current

I = 0.65 A.

Alarm connection

An external alarm can be connected via the high-water level switch.

The cable can stand a control voltage of 250 VAC, 2.5 A.

Cable length

Alarm and power supply cables: 1.7 metres.

Storage temperature

When stored in dry rooms:

- Empty tank: -10 °C to +50 °C.
- Tank with condensate: above 0 °C (risk of frost not allowed).

Ambient temperature

+5 °C to +35 °C.

Liquid temperature

- Average temperature: +50 °C.
- Briefly: maximum +90 °C for 5 minutes.

Operating mode

Intermittent operation:

S3 - 30 %, 1 minute, 60 starts/hour.

Maximum head

5.5 metres.

Maximum flow rate

600 litres/hour.

pH value of condensate

2.5 or higher.

Density of condensate

Maximum 1000 kg/m³.

Motor protection

- Thermal overload switch: +120 °C.
- Insulation class: F.

Enclosure class

IP24.

Weight

2.0 kg.

Volume

- Tank volume: 2.65 litres.
- Useful volume: 0.9 litre.
- Alarm condition: 2.1 litres.
- Operating condition: 1.7 litres.

Dimensions

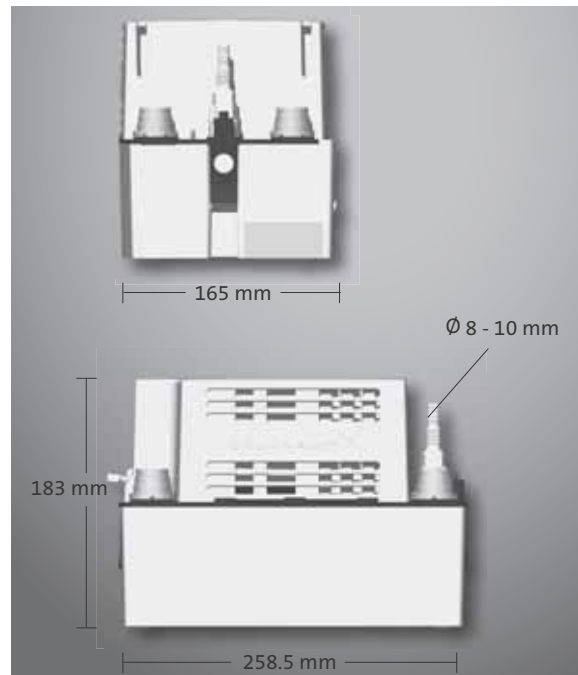

Fig. 13 Dimensions

Performance

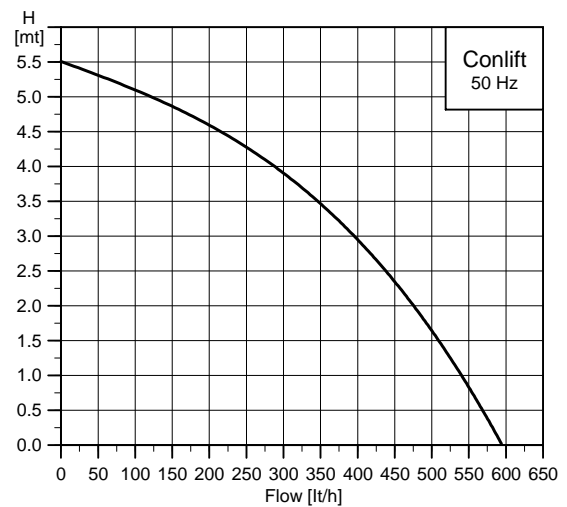

Fig. 14 Performance curve

4. Conlift2 pH+



TM05 1817 3611

Fig. 15 Conlift2 pH+

Applications

The Conlift2 pH+ comes with an integrated acoustic alarm device indicating high-water level. The Conlift2 pH+ is supplied with a neutralisation unit that raises the pH value of the aggressive condensate from below 2.5 to a neutral level. We particularly recommend Conlift2 pH+ for oil boilers generating low pH values and for gas boilers above 200 kW.

Typical applications:

- Condensate boilers. A 200 kW boiler can be drained up to 5 m duty point.
- For condensate with a pH value below 2.5 from gas or oil boilers.
- We recommend to use a neutralisation unit for aggressive condensate in these cases:
 - If the boiler performance is higher than 200 kW.
 - Oil boilers.
 - If the pH value of the condensate is below 2.5.
- For condensate from air-conditioning systems, cooling and refrigeration systems, air dehumidifiers and evaporators.



TM05 1819 3611

Fig. 16 Example of application

Features

- Fully sealed against moisture and evaporation.
- Quick and easy installation.
- Very silent and smooth operation.
- Can be mounted on the floor or on a wall.
- Pre-assembled non-return valve.
- Pump operation test button.
- Incorporates high-water float switch.
- Acoustic high-water alarm device offering the possibility of starting the pump and/or switching the boiler source off.
- Detects kinked discharge hose.
- Fully automatic operation.
- Neutralisation unit with granulate for pH values below 2.5.
- Selectable position of neutralisation unit.
- pH tester for monitoring of the pH level.
- Inlet and discharge hose connectors included.

Sizing guide

Vertical or horizontal pumping

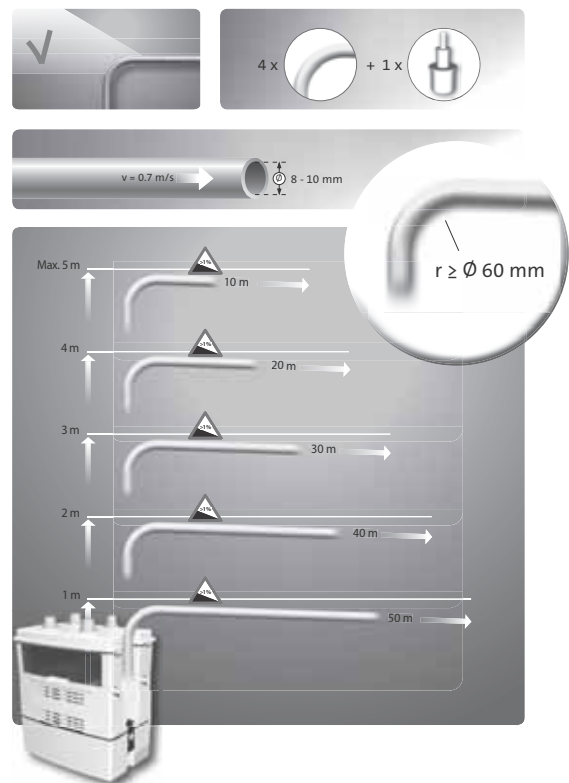

TM05 1818 3611

Fig. 17 Maximum lengths of vertical and horizontal discharge hoses

Figure 17 shows the maximum lengths of vertical and horizontal discharge hoses. The hose length depends on the hose diameter and is based on a flow velocity of 0.7 m/s. Four bends, a non-return valve and an isolating valve have already been taken into account.

Construction features

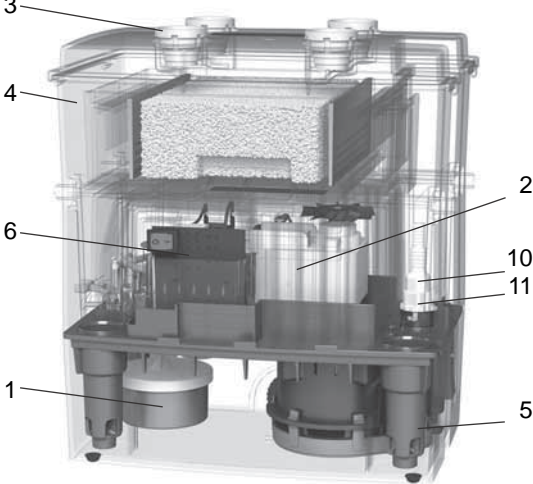
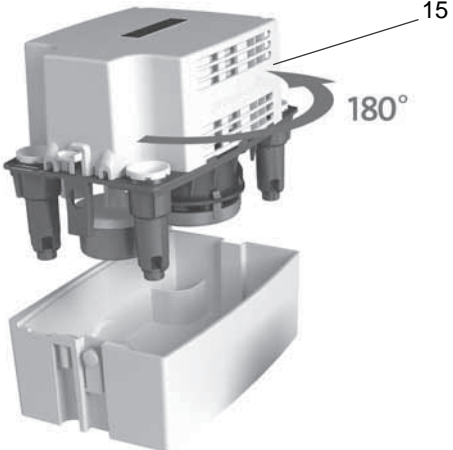
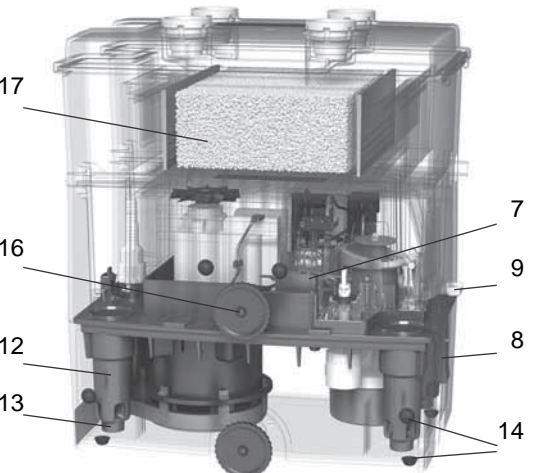
Conlift2 pH+	Description
	Pos. Operational reliability
	1 Special float switch designed to prevent evaporation from tank and corrosion on micro switches.
	2 Motor Stainless-steel motor shaft additionally protected by a shaft seal. Rotating lip seal protecting bearing and motor against evaporation from tank. Built-in motor protection.
	3 Four inlets with grommets to seal and fix the inlet hose.
	4 IP24 cover for protection against splashing water.
	5 Self-venting hydraulics.
	6 Printed-circuit board (PCB) with acoustic alarm device enabling additional pump start.
7 Overflow switch that can be connected to the condensate boiler and set to stop the boiler in case of an alarm.	
	Pos. Easy maintenance and service
	8 Two snap-fasteners enabling easy access to the tank in case of service.
	9 Pump operation test button.
	10 Stepped outlet socket for Ø8 and Ø10 mm hoses.
	11 Non-return valve with bayonet connection for easy service.
	12 Special inlet design preventing sedimentation and evaporation from boiler.
13 Four feet below inlets keeping the sensitive float system load-free in case of service.	
	Pos. Easy installation and replacement
	14 Suitable for wall-hung and floor-standing installation.
	15 180 °-rotatable flange for selection of optimum discharge position.
	16 Alignment wheels enabling easy adjustment in wall-hung installations.
17 Neutralisation unit designed to neutralise the acid condensate coming from gas or oil boilers.	

Installation requirements

This section shows an installation example and describes the installation requirements. Installation is done quickly and easily by using flexible hose connectors with several adapter options for almost any hose diameter.

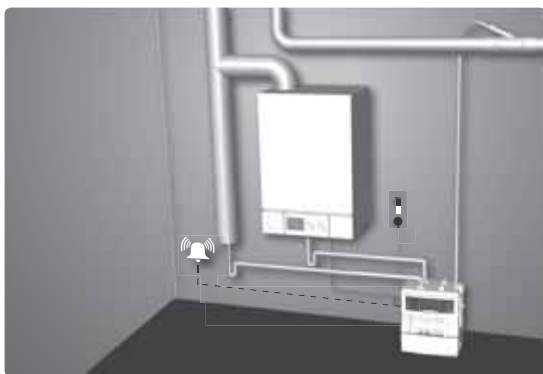

TM05 1820 3611

Fig. 18 Installation example

Connections

Four inlets with grommets to seal and fix the inlet hose. Stepped outlet socket for Ø8 and Ø10 mm hoses.

Product numbers

Product	Schuko plug	Without plug
Conlift2 pH+	97936172	97936175

Accessories

Accessory/ service part	Description	Product number
pH+ Box	Complete neutralisation unit including fitting accessories, neutralisation granulate and pH indicator.	97936176
Extension hose	6 metres of PVC hose with 10 mm internal diameter including one hose coupling.	97936177
Granulate refill package	Granulate, 4 x 1.4 kg and pH indicator	97936178
Alarm PCB Conlift	Printed-circuit board (PCB) enabling additional pump start at alarm level or stop of boiler with acoustic alarm.	97936209

Level control

The liquid level in the tank is controlled automatically by a float switch.

Conlift2 pH+ incorporates a printed-circuit board (PCB) enabling additional functions when the level in the tank reaches the high-water level.

The contact on the PCB can be set to two positions:

Position 1: The pump is started and an acoustic alarm is generated.

Position 0: The condensate source is switched off and an acoustic alarm is generated.

Construction

Sturdy collection tank with four inlets for wall-hung or floor-standing installation. Built-in pump with automatic level control, self-venting hydraulics and free-flow impeller for safe pumping of aggressive condensate with low solid content. The motor, float switch and pump housing are mounted on a service-friendly component bracket on top of the tank.

The additional alarm cable can either be connected to an external alarm system or to a low-voltage circuit for shutdown of condensate source.

Component	Material
Collecting tank	PP
Component bracket and cover	PP
Pump housing	PP
Impeller	PP
Shaft	Stainless steel
Discharge hose	PVC

Included fittings

- 1 inlet adapter, Ø19/32/30 mm
- 4 inlet grommets, Ø18-22 mm
- 1 drain pipe adapter, Ø21.5/40 mm
- screws and plugs for wall-hung installation
- 6 metres of PVC hose, Ø10/14 mm
- 2 alignment wheels
- granulate and pH indicator.

Technical data

Supply voltage

1 x 230 VAC - 6 %/+ 6 %, 50 Hz, PE.
See nameplate.

Input power

P1 = 70 W.

Input current

I = 0.65 A.

Alarm connection

An external alarm can be connected via the high-water level switch.

The cable can stand a control voltage of 250 VAC, 2.5 A.

Cable length

Alarm and power supply cables: 1.7 metres.

Storage temperature

When stored in dry rooms:

- Empty tank: -10 °C to +50 °C.
- Tank with condensate: above 0 °C (risk of frost not allowed).

Ambient temperature

+5 °C to +35 °C.

Liquid temperature

- Average temperature: +50 °C.
- Briefly: maximum +90 °C for 5 minutes.

Operating mode

Intermittent operation:

S3 - 30 %, 1 minute, 60 starts/hour.

Maximum head

5.5 metres.

Maximum flow rate

600 litres/hour.

pH value of condensate

2.5 or higher.

Density of condensate

Maximum 1000 kg/m³.

Motor protection

- Thermal overload switch: +120 °C.
- Insulation class: F.

Enclosure class

IP24.

Weight

2.0 kg.

Volume

- Tank volume: 2.65 litres.
- Useful volume: 0.9 litre.
- Alarm condition: 2.1 litres.
- Operating condition: 1.7 litres.
- Granulate box volume: 1.2 kg.

Dimensions

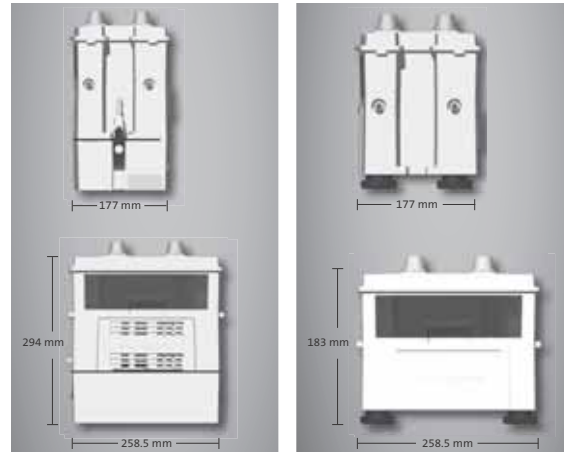

Fig. 19 Dimensions

Performance

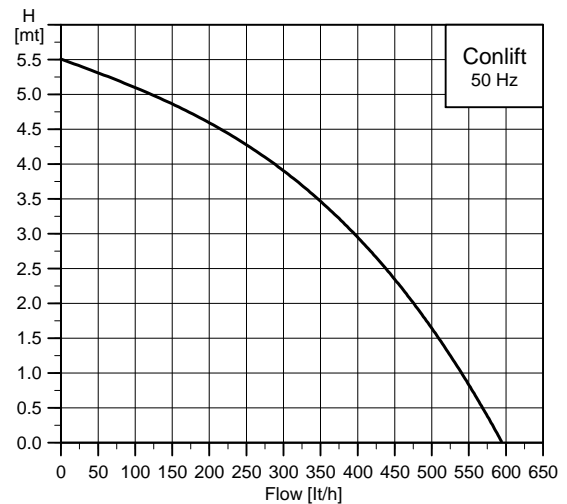

Fig. 20 Performance curve



Sizing

This section is based on different fields of application and installation examples and gives easy step-by-step instructions in how to size a product:

- Select the most suitable and efficient pump for your installation
- Carry out advanced calculations based on energy consumption, payback periods, load profiles, life cycle costs, etc.
- Analyse your selected pump via the built-in life cycle cost tool
- Determine the flow velocity in wastewater applications, etc.



Replacement

In this section you find a guide to selecting and comparing replacement data of an installed pump in order to replace the pump with a more efficient Grundfos pump.

The section contains replacement data of a wide range of pumps produced by other manufacturers than Grundfos.

Based on an easy step-by-step guide, you can compare Grundfos pumps with the one you have installed on your site. When you have specified the installed pump, the guide will suggest a number of Grundfos pumps which can improve both comfort and efficiency.

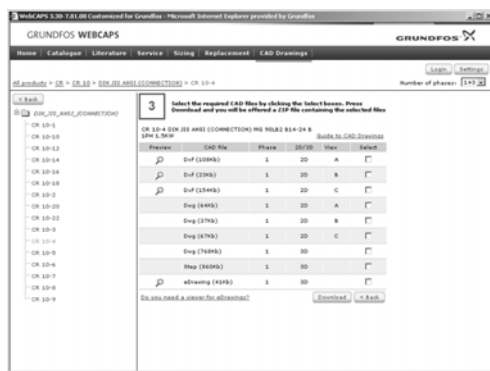

CAD drawings

In this section, it is possible to download 2-dimensional (2D) and 3-dimensional (3D) CAD drawings of most Grundfos pumps.

These formats are available in WebCAPS:

2-dimensional drawings:

- .dxf, wireframe drawings
- .dwg, wireframe drawings.

3-dimensional drawings:

- .dwg, wireframe drawings (without surfaces)
- .stp, solid drawings (with surfaces)
- .eprt, E-drawings.



WinCAPS



Fig. 21 WinCAPS CD-ROM

WinCAPS is a **Windows-based Computer Aided Product Selection** program containing detailed information on more than 220,000 Grundfos products in more than 30 languages.

The program contains the same features and functions as WebCAPS, but is an ideal solution if no internet connection is available.

WinCAPS is available on CD-ROM and updated once a year.

Subject to alterations.

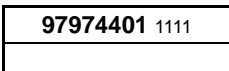

GB

ECM: 1084276

The name Grundfos, the Grundfos logo, and the payoff Be-Think-Innovate are registered trademarks owned by Grundfos Management A/S or Grundfos A/S, Denmark. All rights reserved worldwide.