

Domestic Circulator Pump SE20(60)B

Secondary hot water domestic and commercial circulators SE20B and SE60B.

Glandless circulation pump for pipe installation with constant speed (SE20B) or manual, three-stage speed switchover (SE60B).

Blocking current-proof motor. Optimum performance, reliability and maintenance free operation.

Ideal for single or multi-pump networks. For use in new systems or as a replacement.

Bronze pump housing, glass reinforced plastic impeller, ceramic shaft with carbon bearings.

This circulator is suitable for drinking water only.



Approved fluids:	Potable water and water for foodprocessing companies in accordance with latest TrinkwV (drinking water ordinance)
Temperature range:	2 °C to +65 °C
Max. ambient temp.	+40°C
Rated pressure:	PN 10
Protection class:	IP 44
Mains connection:	1~230 V, 50 Hz



Article-number	Model	BSP	Speed (rpm)	Overall length (mm)	Power consumption (P1)	Amps max. I (A)	Weight (kg)	Pieces per palette
4178916	SE20B	1 ½"	1600-2200	130	38	0.18	2.0	256
4178917	SE60B	1 ½"	1000-2750	130	99	0.43	2.0	256
					74			
					50			

Domestic Circulator Pump SE20(60)B

Curve SE20B

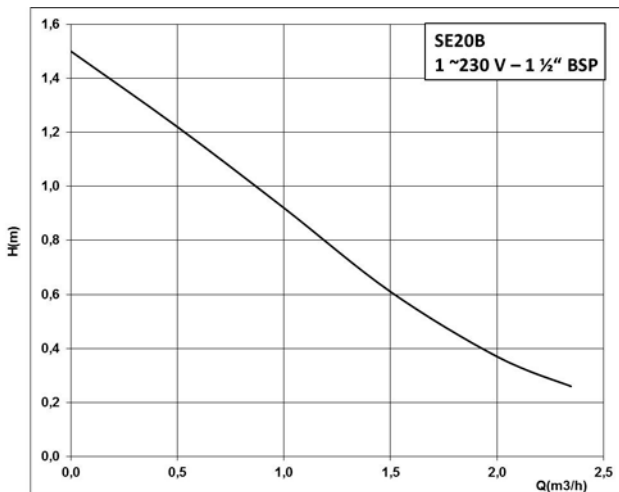

Curve SE60B

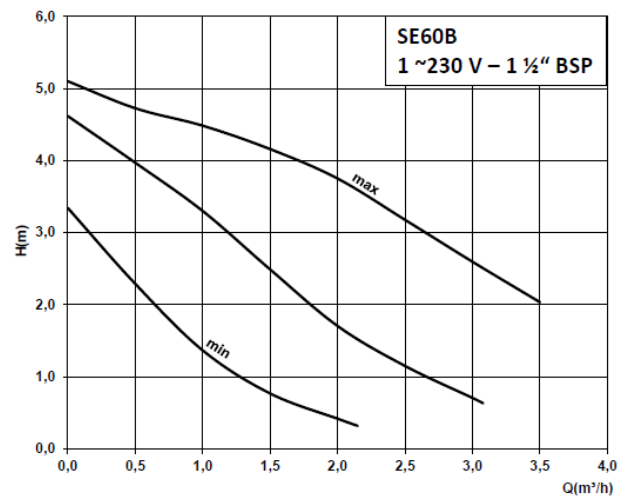

Dimension drawings

Front view

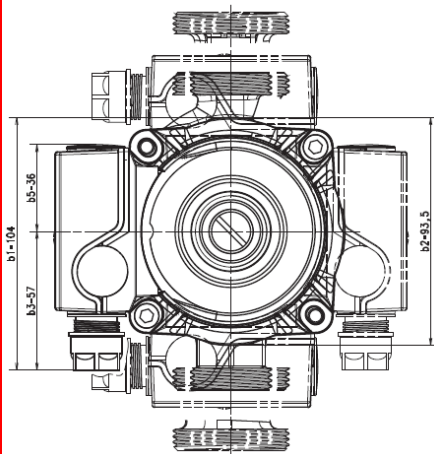

SE20B

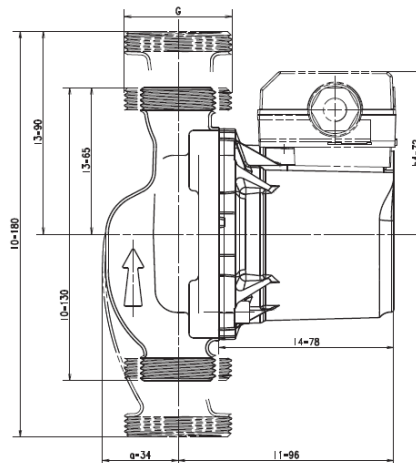

SE60B

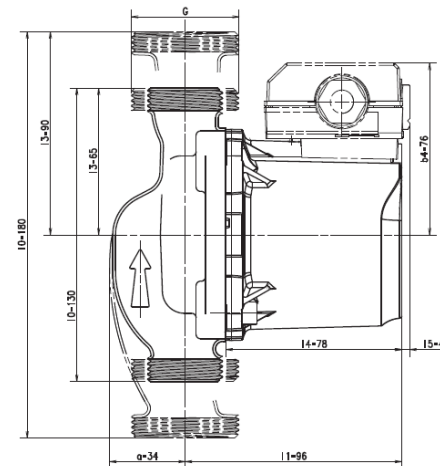

	B1	B2	B3	B4	B5	I0	I1	I3	I4
SE20B	104	93,5	57	72	36	130	96	65	78
SE60B	104	93,5	57	76	36	130	96	65	78

Contact:

Circulating Pumps Limited
 Email: sales@circulatingpumps.co.uk
 Web: www.circulatingpumps.co.uk
 Tel: +44 (0) 1553 764821
 Fax: +44 (0) 1553 815058