

showermate eco

Standard Single Pump

Showermate eco pumps are the ideal solution to boosting the performance of a single shower or outlet, providing an invigorating showering experience.

Designed for domestic use only, Showermate eco pumps will function under positive head conditions and are suitable for installation into open vented hot and cold water systems.

Standard pumps require a flow of just 0.8 l/min to start.



Features

- Durable plastic construction
- 2.0 bar performance
- Automatic switching
- Nitrile/carbon/ceramic seal
- 15 mm push-in flexible hoses with integral isolating valves on inlets
- G 3/4 threaded connections
- Pre-wired with 1.5 metre power cable
- Anti-vibration feet
- 3-year guarantee (subject to conditions)

Application

- Boost the water pressure to either a hot or cold single tap
- Boost the blended water between the shower valve and the shower head

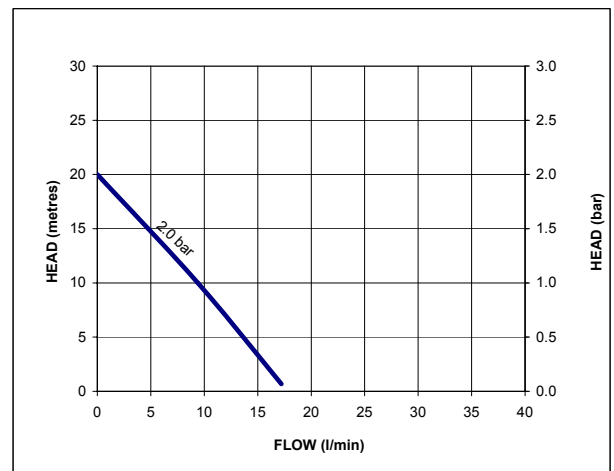

showermate eco

Pump Model		S2.0 bar Single 46503
General	Guarantee	3 years
	WRAS approval	1003059
Features	Pump type	Peripheral
	Mechanical seal	Nitrile / Carbon / Ceramic
	Anti-vibration feet	✓
	Flexible hoses	2
	Dry run protection	✓
Performance	Maximum head (closed valve)	2.0 bar
	Performance @ 9 l/min	1.0 bar
	Performance @ 18 l/min	0.3 bar
	Maximum flow	17 l/min
	Maximum static inlet pressure	10 metres
	Maximum working pressure*	300 kPa (3 bar)
	Maximum ambient air temperature	40 °C
	Min / Max water temperature**	Min 4 °C / Max 65 °C
Flow switch sensitivity (approx)	0.8 l/min	
Connections	Pump connections	G ¾ male
Flexible hoses	Connections	G ¾ female x 15 mm push-in x 200 mm long, isolating valves on inlet hose
Motor	Type	Induction, auto-reset thermal trip
	Duty rating	Int (S3) 30 mins on/30 mins off @ 9 l/min
Electrical	Power supply / phase / frequency	230 V a.c. / 1 / 50 Hz
	Current (full load)	1.0 Amps
	Power consumption	215 Watts
	Fuse rating	5 Amps
	Power cable (pre-wired)	1.5 metres
Physical	Enclosure protection	IP22
	Length	208 mm
	Width	132 mm
	Height (excluding hoses)	166 mm
	Weight (including fittings)	3.3 Kg

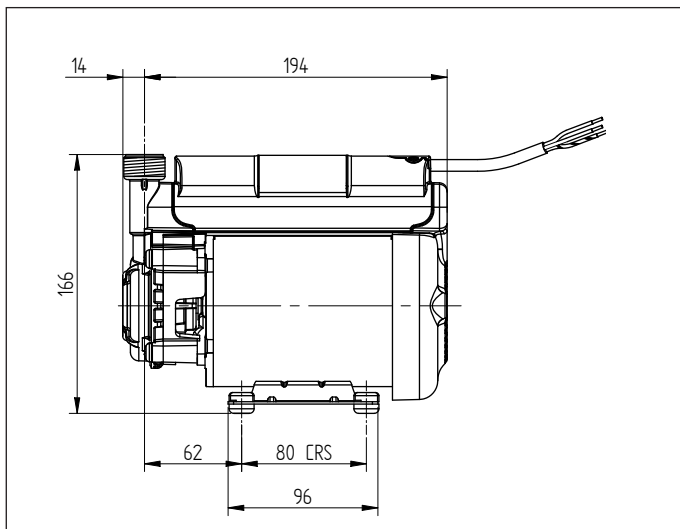

* The maximum pressure that can be applied to the pump under any installation conditions.

** A stored water temperature of 60 °C is considered sufficient to meet all normal requirements and will minimise deposition of scale in hard water areas.

Stuart Turner Limited reserves the right to amend specifications without notice.