

STUART TURNER LTD HENLEY-ON-THAMES.

THIRD ANGLE PROJECTION

DIMENSIONS IN MILLIMETRES

MOTOR FOOT DETAIL
SCRAP VIEW ON ARROW 'X'
(UNDERSIDE OF BASE)
SCALE 1:1

6 SLOTS 7 mm WIDE

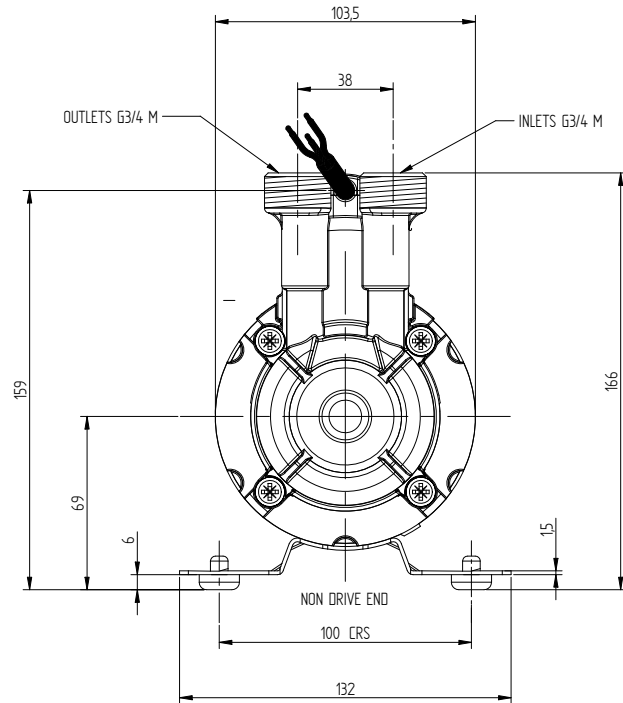
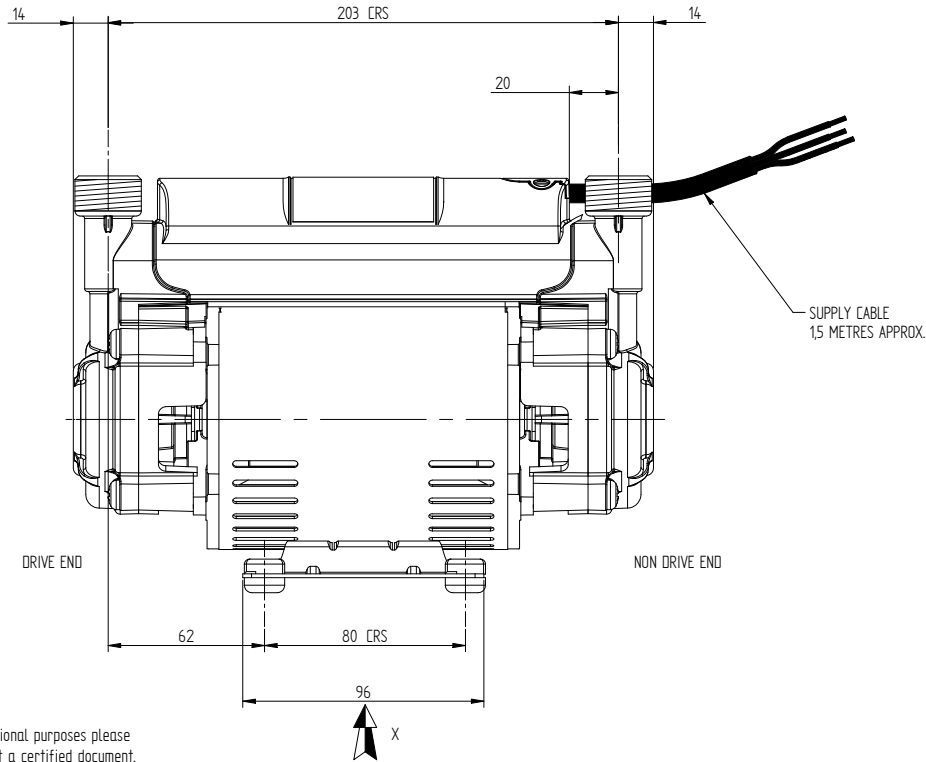
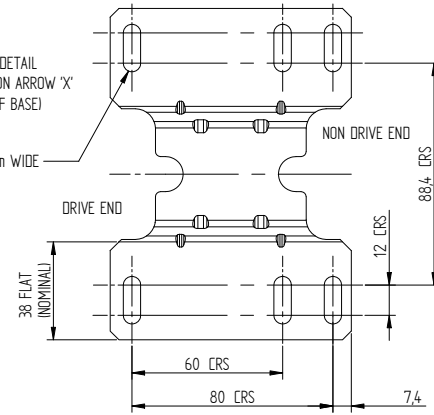

If drawing is to be used for constructional purposes please contact Stuart Turner Ltd and request a certified document.

Stuart Turner Ltd reserves the right to amend specifications without notice.

Stuart Turner Ltd own the copyright within this document. The document may be printed for personal use only. The document must not be altered, reproduced or utilized in any way without written permission from Stuart Turner Ltd, Henley-on-Thames, Oxon, UK.

GENERAL ARRANGEMENT OF A SHOWERMATE ECO 1.5 & 2.0 bar TWIN

W46500

DATE: 24/11/09