

showermate

Universal Single Pump

Showermate pumps are the ideal solution to boost the performance of single shower applications to provide an invigorating showering experience.

Designed for domestic use only, Showermate Universal pumps will function under both positive and negative head conditions and are suitable for installation into open vented hot and cold water systems.

Universal pumps do not require a gravity flow of water to start.



Features

- Durable plastic construction
- 2.6 bar performance
- Automatic switching
- Nitrile/carbon/ceramic seal
- Fully automatic
- 15 mm push-in flexible hoses with integral isolating valves on inlets
- G 3/4 threaded connections
- Pre-wired with 1.5 metre power cable
- Anti-vibration feet
- 3-year guarantee (subject to conditions)

Application

- Boost the water pressure in either the hot or cold supply

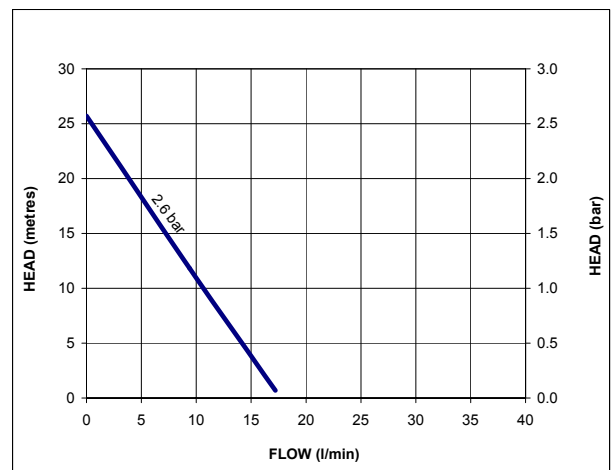

showermate

Pump Model		U2.6 bar Single 46534
General	Guarantee	3 years
	WRAS approval	1212078
Features	Pump type	Peripheral
	Mechanical seal	Nitrile / Carbon / Ceramic
	Anti-vibration feet	✓
	Flexible hoses	2
	Run on Timer	3 sec
	Dry run protection	✓
Performance	Maximum head (closed valve)	2.6 bar
	Performance @ 9 l/min	1.3 bar
	Performance @ 18 l/min	0.3 bar
	Maximum flow	18 l/min
	Maximum static inlet pressure	6 metres
	Maximum static outlet pressure	6 metres
	Maximum working pressure*	380 kPa (3.8 bar)
	Maximum ambient air temperature	40 °C
	Min / Max water temperature**	Min 4 °C / Max 65 °C
	Flow switch sensitivity (approx)	0.8 l/min
	Pressure vessel air pre-charge	1.5 bar (21.75 psi)
Connections	Pump connections	G ¾ male
Flexible hoses	Connections	G ¾ female x 15 mm push-in x 200 mm long, isolating valves on inlet hose
Motor	Type	Induction, auto-reset thermal trip
	Duty rating	Int (S3) 30 mins on/30 mins off @ 9 l/min
Electrical	Power supply / phase / frequency	230 V a.c. / 1 / 50 Hz
	Current (full load)	1.2 Amps
	Power consumption	280 Watts
	Fuse rating	5 Amps
	Power cable (pre-wired)	1.5 metres
Physical	Enclosure protection	IPX4
	Length	233 mm
	Width	139 mm
	Height (excluding hoses)	338 mm
	Weight (including fittings)	4.7 Kg

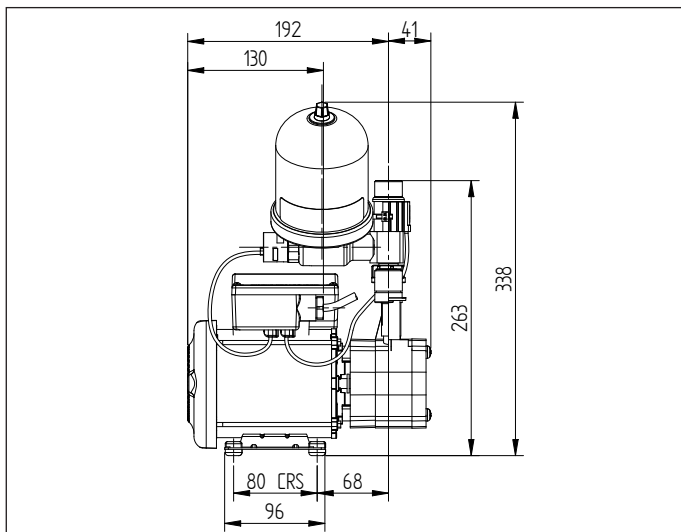

* The maximum pressure that can be applied to the pump under any installation conditions.

** A stored water temperature of 60 °C is considered sufficient to meet all normal requirements and will minimise deposition of scale in hard water areas.

Stuart Turner Limited reserves the right to amend specifications without notice.