

Installation, Operation & Maintenance Instructions

Please leave this instruction booklet with the home owner as it contains important guarantee, maintenance and safety information



Read this manual carefully before commencing installation.

This manual covers the following products:

Supersub 150VA
Pt. No. 46538

Supersub 250VA
Pt. No. 46539



PRODUCT DESCRIPTION

Electric motor driven submersible pump with float switch control.

APPLICATION

The submersible pump range is designed for re-circulation, drainage and transfer of fresh water in outdoor or indoor applications.

The pumps incorporate an integral float switch, which provides automatic pump control in the form of a low level cut out to prevent the risk of dry running.

The pumps are suitable for dirty water applications and are capable of handling semi-solids in suspension of up to *5 mm in diameter.

*Note: Applicable only when pump is suspended above bottom of sump. When pump is located on the bottom of sump the inlet grille will restrict solid ingress diameters to 3 mm.



- **The pumps must not be used with salt water, sewage, flammable, corrosive or explosive liquids (eg. petroleum oil, petrol, thinners) grease, oils or foodstuffs.**
- **This appliance can be used by children aged from 8 years and above and persons with reduced physical, sensory or mental capabilities or lack of experience and knowledge if they have been given supervision or instruction concerning use of the appliance in a safe way and understand the hazards involved. Children shall not play with the appliance. Cleaning and user maintenance shall not be made by children without supervision.**
- **Children should be supervised to ensure that they do not play with the appliance.**

Please read installation details carefully as they are intended to ensure this product provides long, trouble free service. Failure to install the unit in accordance with the installation instructions will lead to invalidation of the warranty.

STORAGE

If this product is not to be installed immediately on receipt, ensure that it is stored in a dry, frost and vibration free location in its original packaging.

CONTENTS Page

- Checklist 4
- Important Facts - read before commencing installation 5
- Location 6
- Pump Connections 8
- Electrical Installation 9
- Commissioning 10
- Maintenance 11
- Technical Specification 13
- Trouble Shooting 14
- Guarantee 15

CHECKLIST

IMPORTANT: With the pump removed from its packaging check for any damage prior to installation. If any damage is found contact Stuart Turner Ltd within 24 hours of receipt.

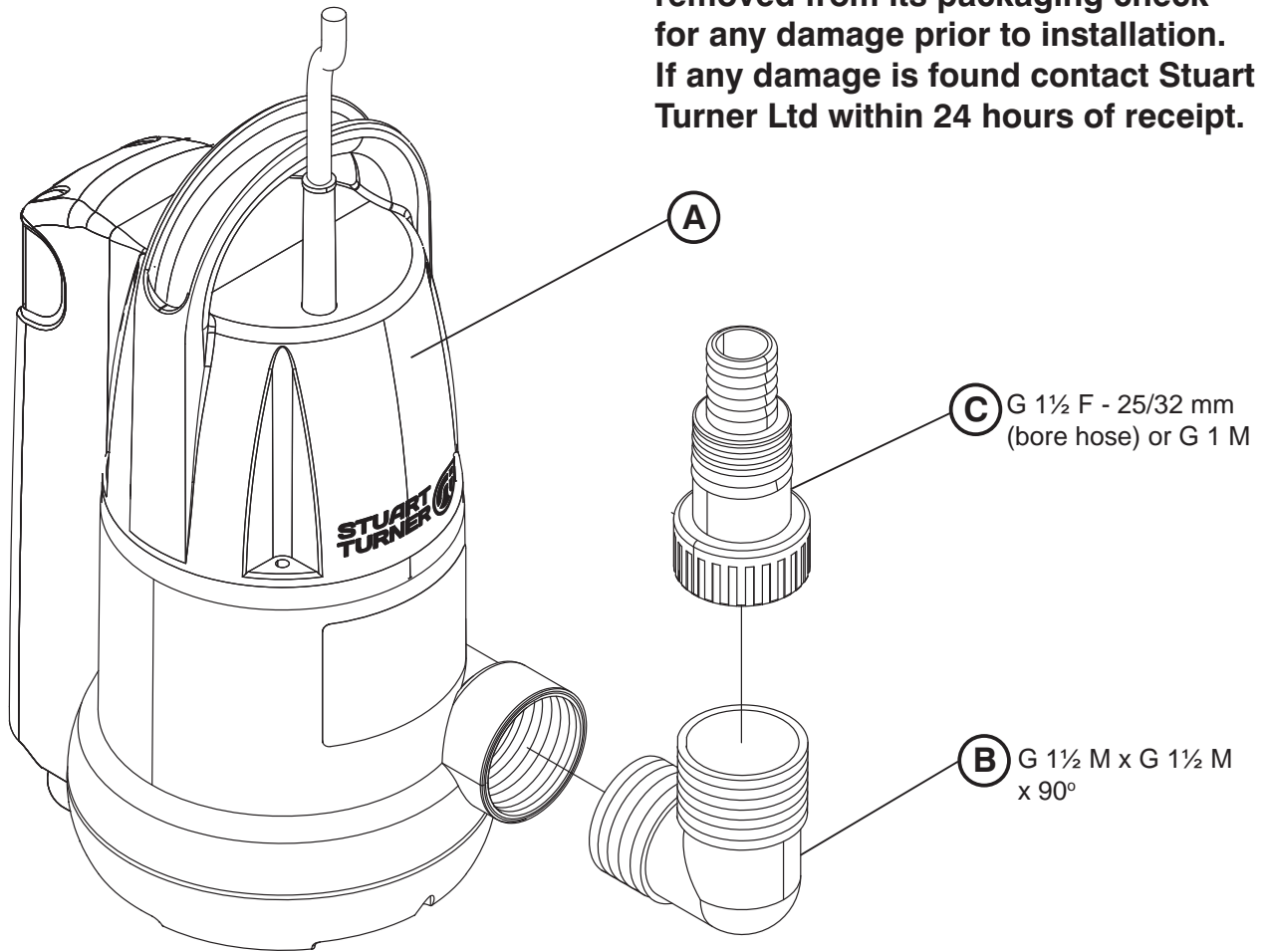

Fig. 1

Item	Description	Qty	Item	Description	Qty
(A)	Pump	1	(C)	Connector	1
(B)	Elbow	1			

Your product may vary slightly from the picture above.

Cont ...

1 READ BEFORE COMMENCING PUMP INSTALLATION

A. Water temperature

The water entering the pump must be controlled as follows:

1.11 The maximum allowable water temperature is 35 °C.

1.12 The minimum allowable water temperature is 4 °C.

B. Pipework - General

1.13 All models are supplied with a 90° elbow and stepped hose connector (see pump connection section for details) which can be screwed directly into the pump discharge connection.

1.14 The hose connector is suitable for a range of flexible hose sizes and can be cut to suit the selected size. For best flow use the largest bore pipe possible minimising 90° bends. Small pipe sizes will reduce the pump performance.

C. Plumbing & Electrical Installation Regulations

1.15 The electrical installation must be carried out in accordance with the current national electrical regulations.

1.16 The electrical installation must be installed by a qualified person.

2 LOCATION - GENERAL



- 2.11 **Access:** For emergencies and maintenance the pump must be easily accessible.
- 2.12 Do not run against a closed valve for periods longer than 5 minutes. The water in and around the pump must not be allowed to freeze. This will result in pump damage.
- 2.13 Do not under any circumstances use the supply cord fitted, as a means to carry or lower the pump into position on installation. Attach a rope sling to handle.
- 2.14 **Pump position:** When siting the pump ensure its base is raised slightly from the bottom of the sump reducing the possibility of blocking the filter with debris or drawing in small stones (see Fig. 2).

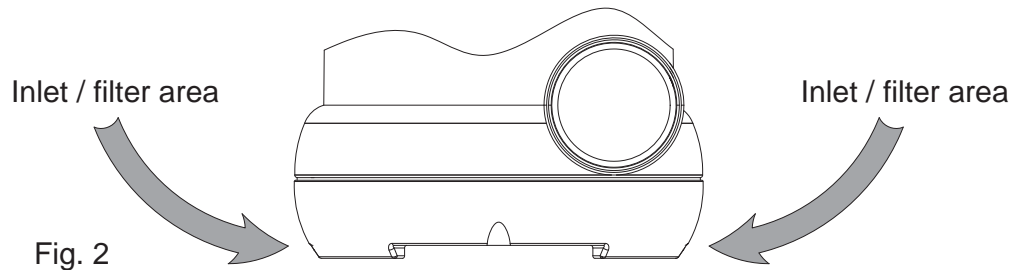

- 2.15 The pump must be installed in the vertical position and must be fully submerged at all times when operating continuously to avoid overheating of the motor. However, when the automatic float switch option is selected, the pump may be operated partially submerged for short periods (see float switch operation section for further details).
- 2.16 When siting the pumps in a location where organic or general debris is likely, ensure the pump is placed on its base on a flat horizontal surface (eg. on a paving slab) to enable full functionality of the inlet filter grille and to prevent the force of the pump from drawing in small stones. **This will result in pump damage.**
- 2.17 **Float Switch:** The pumps incorporate an integral automatic float switch which has two modes of operation, auto and manual. The float switch consists of a float which moves up and down on a vertical axis within a housing.
- 2.18 **Sump Size:** The minimum possible sump size is 270 mm x 170 mm.

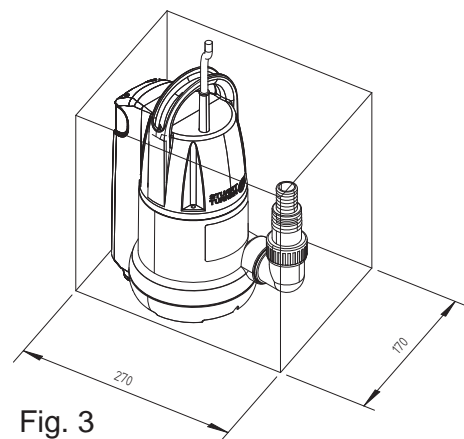

Cont ...

- 2.19 **Float Switch Operation:** The float switch operation mode is changed by moving the selection lever (1) either up for the Manual position or down for the Auto position.
- 2.20 **Automatic Operation (Switch Position 'Down'):** The integrated float starts and stops the pump automatically when the selection indicator is set to automatic. It also provides a low level cut out to prevent dry running.
- 2.21 **Manual Operation (Switch Position 'Up'):** To start the pump, lift the selector lever (1) to the up position. This will cause the pump to run continuously. In this condition the pump will empty the sump down to a level of 3-6 mm.
The pump must then be stopped to avoid dry running and pump damage.

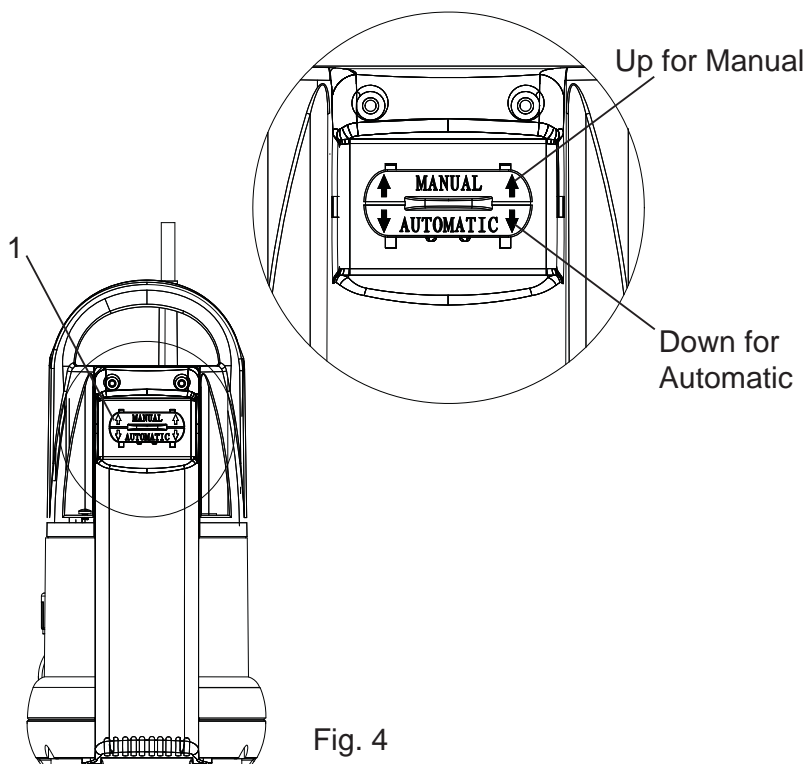

Fig. 4

2.22 **Water Levels:**

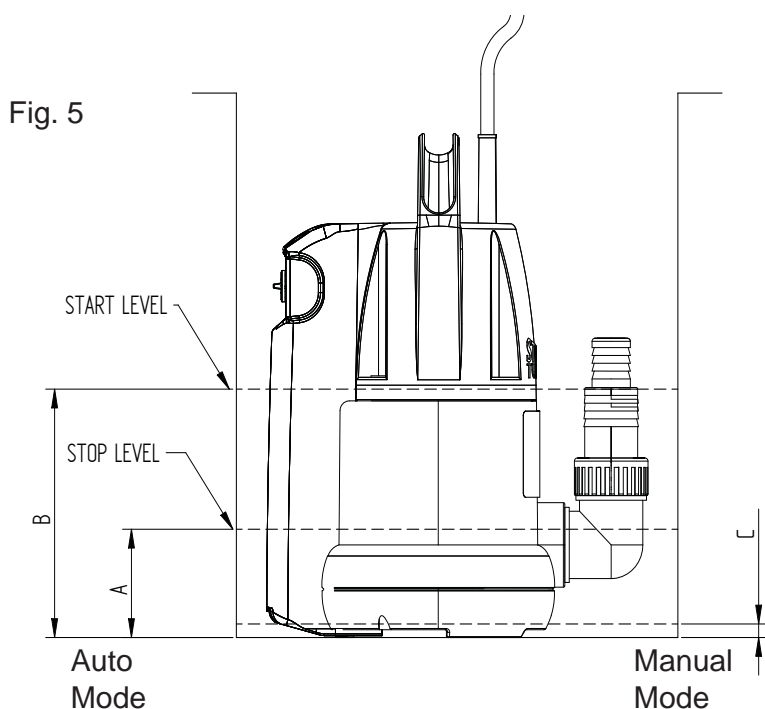

Fig. 5

Automatic Operation

Model	Dim. A	Dim. B
All	75	150

Manual Operation

Model	Dim. C
All	3-6 mm (see note)

Note: Pump **must** be stopped at this level to prevent damage.

Cont ...

CONNECTIONS

Supersub pumps are supplied with an elbow and stepped hose connector which can be screwed to the pump outlet port.

Pump Type	Pump Outlet	Elbow	Hose Connector	
			Thread	Hose Bore (mm)
Supersub	G1½ F	G1½ M x G1½ M x 90°	G1½ / G1 F	25 / 32 / G 1 M

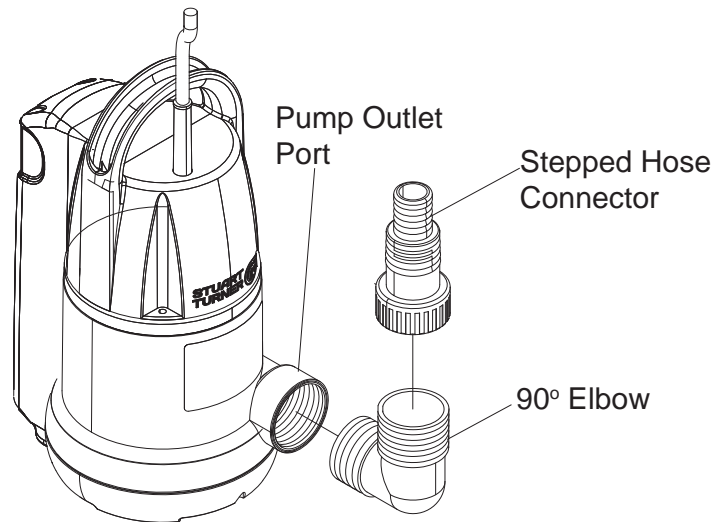

Fig. 6

4 ELECTRICAL INSTALLATION



- 4.11 **Regulations:** The electrical installation must be carried out in accordance with the current national electrical regulations and installed by a qualified person.
- 4.12 **Safety:** In the interests of electrical safety a 30 mA residual current device (**R.C.D. not supplied**) should be installed in the supply circuit. This may be part of a consumer unit or a separate unit.
- 4.13 Before starting work on the electrical supply ensure power supply is isolated.
- 4.14 Isolate all appliances in the water from the electrical supply before putting your hands in the water.
- 4.15 The power supply cord of this pump cannot be replaced. If the cord is damaged, the pump should be disposed of (see Section 8.11).
- 4.16 If the pump is used to empty a swimming pool, the pump must not be used when people are in the water.
- 4.17 All motors are thermally protected by an integral auto-resetting thermotrip and are rated for continuous use.
- 4.18 **Earthing:** This appliance must be earthed via the supply cord.
- 4.19 **Connections:** The motor is provided with a factory fitted supply cord and plug. This must be connected to the mains supply via a 13 Amp double pole switched, socket outlet in compliance with BS 1363-2.
The socket outlet should be mounted in an easily accessible position and should be labelled if confusion is possible, to allow easy identification of the pump isolating switch.
- 4.20 **Wiring Of Connection Unit:**
The moulded plug fitted to this appliance is not waterproof - keep dry.
If the plug supplied is not suitable for your socket outlet, it should be cut off and destroyed.
A plug with bared flexible cords is hazardous if engaged in a live socket outlet.
The end of the flexible cord should be suitably prepared and correct plug fitted, as follows:
The wires in this mains lead (supply cord) are coloured in accordance with the following code:
Green & Yellow: Earth Blue: Neutral Brown: Live
As these colours may not correspond with the coloured markings identifying the terminals in your plug, proceed as follows:
The wire which is coloured green and yellow must be connected to the terminal in the plug which is marked with the letter 'E' or by the earth symbol \oplus or coloured green or green and yellow.
The wire which is coloured blue must be connected to the terminal which is marked with the letter 'N' or coloured black or blue.
The wire which is coloured brown must be connected to the terminal which is marked with the letter 'L' or coloured brown or red.
- 4.21 **Fuses:** The following fuse size should be used with the appropriate pump.

Model	Fuse Size (AMPS)
All Models	13

Cont ...

4.22 **Supply Cord Extension:** The pumps are fitted with a supply cord suitable for outdoor and underwater use. The cord specification is as follows:-

Pump Type	Cord Type	Cord Length (m)
All Models	HO5RN-F3 G 0.75 mm ²	10

If an extension cord is necessary a cord of the proper type and rating must be used.

In general for 230 volt pumps on distances up to 40 metres (inclusive of original cord length) the same specification cord as fitted to the pump can be used. For distances above 40 metres a larger cord size may be required due to voltage drop and advice must be obtained based upon installation details.

Any connectors or junction boxes must be specifically suited for outdoor use and installed in accordance with manufacturers instructions.

Any cable routed underground must be protected to local standards.

5 COMMISSIONING

5.11 The pump chamber must be full of water at all times. Damage will result if pump runs dry.

5.12 The pump must be fully submerged before starting. Take care when submerging the pump to ensure all air is purged from the casing. This is done by slowly submerging the pump and gently agitating whilst doing so. This will enable any trapped air pockets to be released.

5.13 Turn on the electrical supply and water movement should be immediately evident from pump outlet. If it is not, repeat step 5.12.

5.14 **For Further Technical Support:** Phone the Stuart Turner PumpAssist team on 0844 98 000 97. Our staff are trained to help and advise you over the phone. Note: When pumps are installed in another manufacturers original equipment, please contact the manufacturer for advice.

6 MAINTENANCE

- 6.11 The water in and around the pump must not be allowed to freeze. This will result in pump damage.
- 6.12 Provision should be made for easy access to the pump to allow for regular maintenance.
- 6.13 The integral inlet filter grille should be checked periodically and cleaned if required. It is important the filters are clean and free from debris which in turn ensures the pump will always run at maximum efficiency. A blocked filter can cause damage to the pump
- 6.14 The pump must be cleaned as follows:-
- 6.15 **Pump Cleaning:**
- 1) Disconnect electrical supply before working on pump.
 - 2) Release system pressure from pipework and remove pump from water (do not use cable to lift pump).
 - 3) Clean integral inlet filter grille using water pressure from a hose pipe.
 - 4) Refer to commissioning section for instructions on re-starting pump.

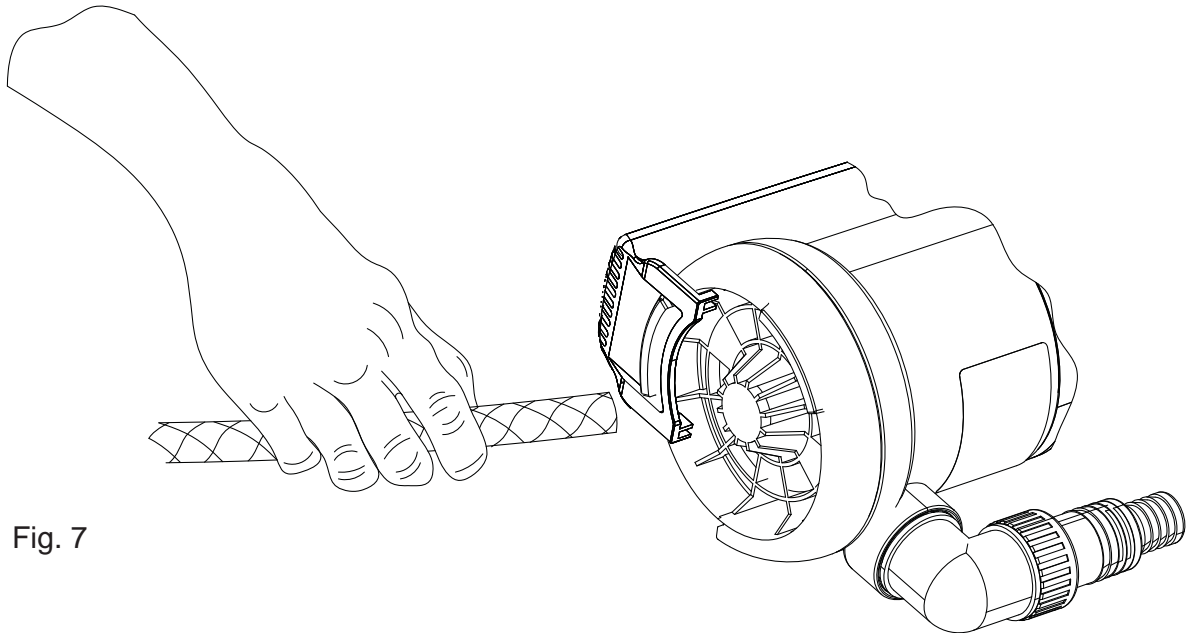
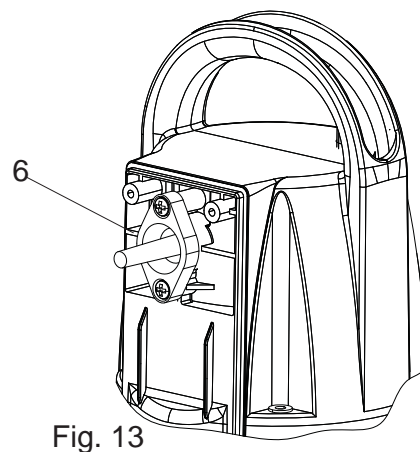
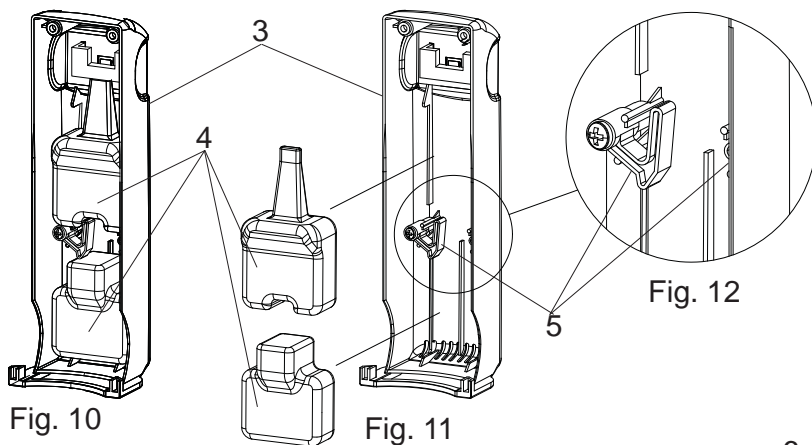
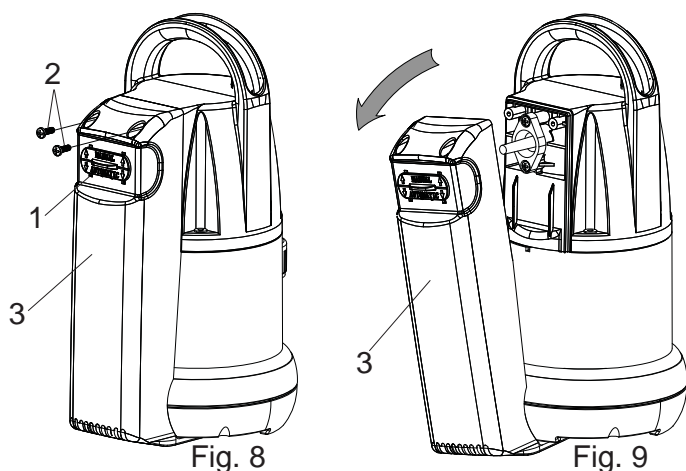

Fig. 7

6.16 Float Switch Cleaning:

The float switch assembly can be cleaned as follows:-

- 1) Move the selector (1) to the 'Automatic' (down) position Fig. 8.
- 2) Remove the two screws (2) located in recesses at the top of the float housing (3) Fig. 8.
- 3) Gently pull the float housing (3) away and down from the pump body - **DO NOT INVERT** float housing (3) Fig. 9.
- 4) Note the position of the two floats (4) within the float housing (3) Fig. 10.
- 5) Remove and clean the floats (4) Fig. 11.
- 6) Clean the inside of the float housing (3) and the float ratchet stops (5) ensure these stops are clear of all debris and free to move Fig. 11 & 12.
- 7) Clean around switch protrusion (6) Fig. 13.
- 8) Reassembly is the reverse of the above procedure.
- 9) Refer to commissioning section to re-start the pump.



Cont ...

7 TECHNICAL SPECIFICATION

Model		Supersub 150VA	Supersub 250VA
Electrical	Power supply Volts/phase frequency	230/1/50	230/1/50
	Enclosure	IPX8	IPX8
	Type of motor	Induction	Induction
	Power consumption	275 watts	508 watts
	Full load current	1.2 Amps	2.2 Amps
	Rating	Continuous	Continuous
	Max. No Starts per hour	30	30
Mechanical	Max head (closed valve)	6.5 metres	8.5 metres
	Max immersion depth	7 metres	7 metres
	Min immersion depth	Fully submerged	Fully submerged
	Max water temperature	35 °C	35 °C
	Min water temperature	4 °C	4 °C
Pump Dimensions	Diameter	158 mm	158 mm
	Height (excluding flexible hoses)	320 mm	320 mm
	Weight (including flexible hoses)	4.6 Kg	4.8 Kg
	Pump Connections: Outlet	G 1½ Female	G 1½ Female
	Hose connector	G 1½ Female / G 1 Male / 25 or 32 mm bore hose	
Materials	Body	Glass filled polypropolene	Glass filled polypropolene
	Shaft	Stainless steel	Stainless steel
	Mechanical Seal	Double Lip	Double Lip
	Pump Parts	Polyamide Impeller	Polyamide Impeller

Stuart Turner reserve the right to amend the specification in line with its policy of continuous development of its products.

7.11 **Noise:** The equivalent continuous A-weighted sound pressure level at a distance of 1 metre from the pumpset does not exceed 70 dB(A).

Cont ...

8 TROUBLE SHOOTING GUIDE

Symptoms	Probable Cause	Recommended Action
Pump stops running.	Thermal overload protection has tripped.	<p>Disconnect the power supply to the pump.</p> <p>Check to ensure the pump is connected to the correct voltage supply.</p> <p>Check to ensure the impeller is not jammed and can rotate freely.</p> <p>Check to ensure water to be pumped does not exceed recommended temperature, ensure pump has not run dry and is fully submerged if running continuously.</p> <p>Check probable causes and remedy, allow to cool reinstall and connect cable.</p>
Pump will not start.	<p>Power not connected to the electricity supply.</p> <p>Impeller Jammed.</p> <p>Float switch not working.</p> <p>Water level under minimum requirements.</p>	<p>Check the cable is connected correctly and power supply is switched on. Check fuse.</p> <p>Clean away debris from the impeller.</p> <p>Ensure float can move freely.</p> <p>Increase the depth of the sump.</p>
<p>Pump runs but no water is supplied.</p> <p>or</p> <p>Poor performance.</p>	<p>Low water level.</p> <p>Impeller jammed.</p> <p>Discharge pipe clogged.</p> <p>Suction filter blocked.</p> <p>Required head is too high for the pump characteristics.</p>	<p>Ensure the pump is fully submerged in the water.</p> <p>Free obstruction Ensure that the pump is not able to suck air in (low water level).</p> <p>Remove pipe and ensure the discharge is clear of any debris.</p> <p>Check inlet pre-filters, (if fitted), and integral inlet grille are free from blockage.</p> <p>Refer to limits of application section.</p>
Pump will not stop.	Pump is not disabled by the float.	Ensure float can move freely.

8.11 Environment Protection: Your appliance contains valuable materials which can be recovered or recycled.

At the end of the products' useful life, please leave it at an appropriate local civic waste collection point.

Cont ...

9 THE GUARANTEE - 1 YEAR

Stuart Pumps are guaranteed by Stuart Turner Limited to be free from defects in materials or workmanship for the applicable guarantee period from the date of purchase. The applicable guarantee period is stated in the installation booklet supplied with the pump. Within the guarantee period we will repair, free of charge, any defects in the pump resulting from faults in material or workmanship, repairing, exchanging parts or exchanging the whole unit as we may reasonably decide.

Not covered by this guarantee: Damage arising from incorrect installation, improper use, unauthorised repair, normal wear and tear and defects which have a negligible effect on the value or operation of the pump.

Reasonable evidence must be supplied that the pump has been purchased within the applicable guarantee period prior to the date of claim (such as proof of purchase or the pump serial number).

This guarantee is in addition to your statutory rights as a consumer. If you are in any doubt as to these rights, please contact your local Trading Standards Department or Citizen's Advice Bureau.

In the event of a claim please telephone Stuart Turner Limited on 0844 980 0097 or return your pump with accessories removed, plugs, pipes etc. If you have any doubt about removing a pump, please consult a professional.

Proof of purchase should accompany the returned pump to avoid delay in investigation and dealing with your claim.



DECLARATION OF CONFORMITY

2006/95/EC

BS EN 60335-1, BS EN 60335-2-41, EN 50366

2004/108/EC

BS EN 55014-1, BS EN 55014-2, BS EN 55022, BS EN 61000-3-2, BS EN 61000-3-3,
BS EN 61000-4-2, BS EN 61000-4-3, BS EN 61000-4-4, BS EN 61000-4-5, BS EN 61000-4-6,
BS EN 61000-4-11

2011/65/EU

IT IS HEREBY CERTIFIED THAT THE STUART ELECTRIC MOTOR DRIVEN PUMP COMPLIES WITH THE ESSENTIAL REQUIREMENTS OF THE ABOVE E.E.C. DIRECTIVES.

RESPONSIBLE PERSON
AND MANUFACTURER

STUART TURNER LIMITED
HENLEY-ON-THAMES, OXFORDSHIRE
RG9 2AD ENGLAND.

Signed.......... Business Development Director

Stuart Turner are an approved company to BS EN ISO 9001:2000



Stuart Turner Ltd, Henley-on-Thames, Oxfordshire RG9 2AD ENGLAND

Tel: +44 (0) 1491 572655, Fax: +44 (0) 1491 573704

info@stpumps.co.uk www.stuart-turner.co.uk

V.A.T. REG. No. 199 0987 92. Registered in England No. 88368. Registered Office: Market Place, Henley-on-Thames