

Wasteflo WC2 - Macerator

The Wasteflo WC2 macerator is ideal when creating a simple cloakroom with a toilet and wash basin. Its attractive and slim design is fully compatible with standard and slimline sanitaryware.

Application

Macerators are a simple way to pump waste water from a sanitary appliance where there is no local access to a soil pipe.

Features & Benefits

- Easy to fit.
 - The slimline design of the Wasteflo macerator enables it to fit behind a WC whilst allowing the cistern to be fixed directly to the wall without the use of battens.
 - WC coupling is adjustable to accommodate variations in toilet position and is push-fit. No clips or tools are required.
 - Outlet connection is adjustable to suit a range of waste pipe sizes.
- Easy to maintain.
 - An innovative watertight cassette unit enables easy removal, cleaning and maintenance of the working parts without having to remove the WC, cistern or pipework.

Specification

- One toilet pan connector with innovative inbuilt height adjustment (± 16 mm).
- One side inlet suitable for 32 mm (1¼ ") waste pipe to connect to a basin (40 mm (1½ ") inlet adaptor included).
- Outlet - suitable for 32 mm, 28 mm or 22 mm waste pipe.
- Pumps up to 5 m vertically or 52 m horizontally.
- Maximum flow rate of 90 l/min.
- Complies with BS EN 12050.
- Less than 60 dB noise level.
- Supplied pre-wired with 1.5 m supply cable.
- Full range of spares available.

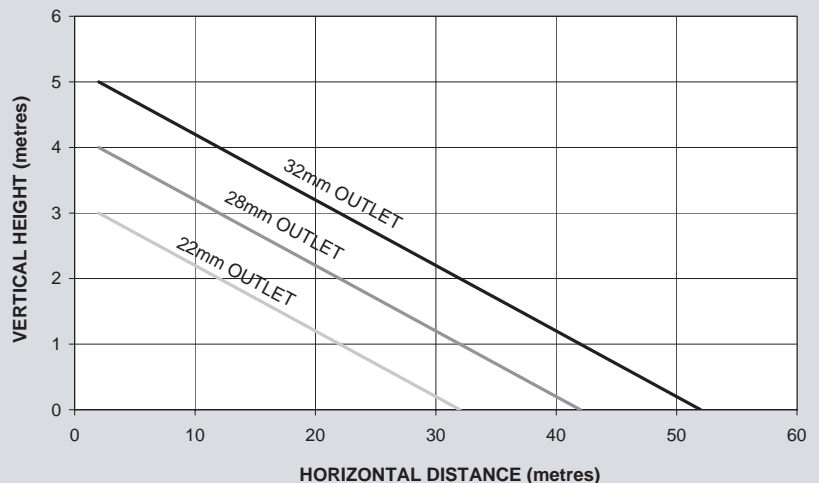
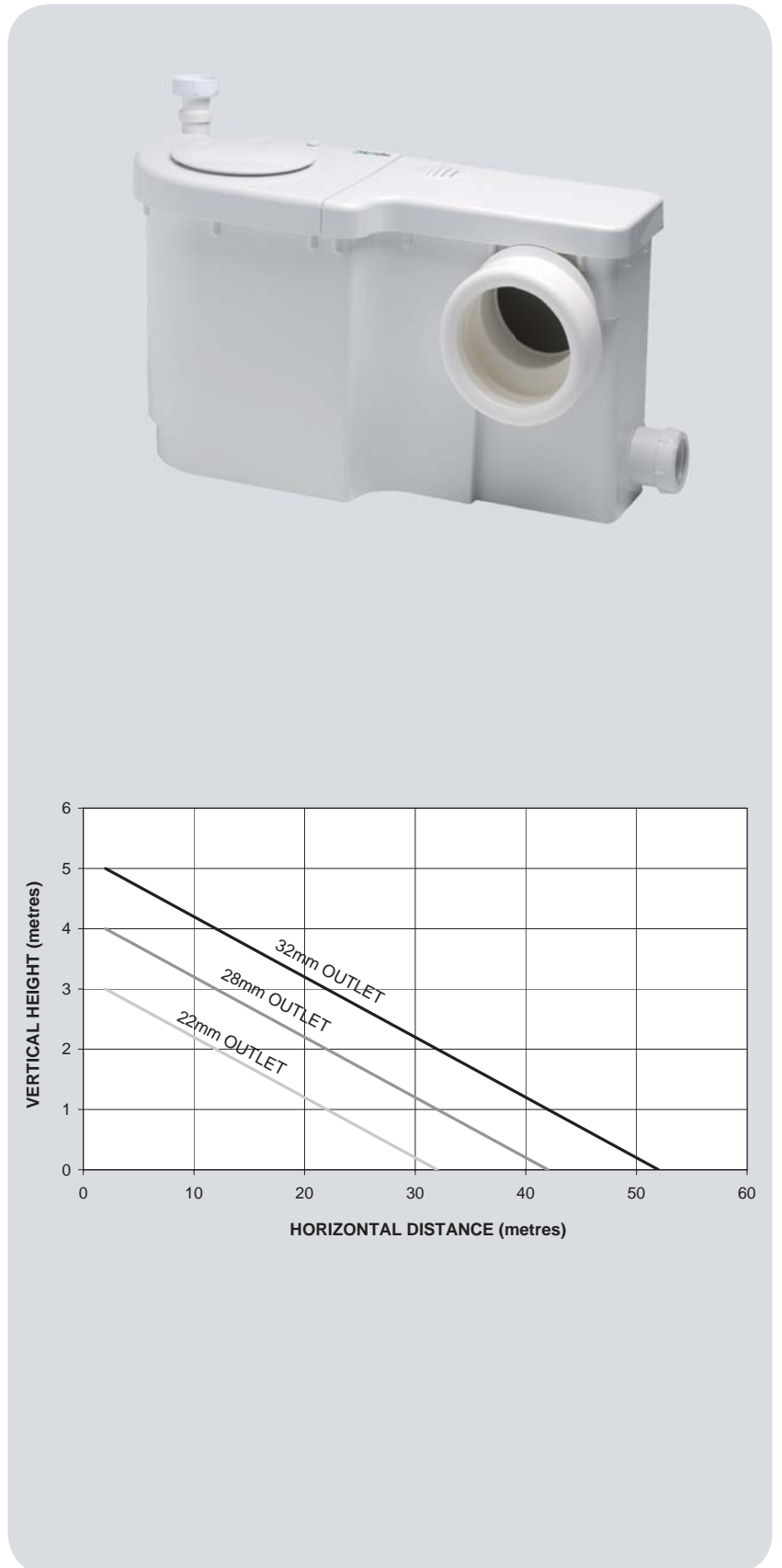

Wasteflo WC2 - Macerator

Model	Motor	Max. watts consumed	Amps full load	Carton dims. mm			Gross weight (packed) kg	Part no.
				L	W	H		
WC2	230/1/50	500	2.2	580	270	385	9.8	46575

Materials

Polypropylene, stainless steel, evoprene

Operating Conditions

Max. liquid temp.	50°C
Min. liquid temp.	4°C
Suction	Flooded
Max. ambient air temp.	40°C

Pump Connection Sizes

Inlet	32 mm (1 1/4")
Outlet	32 mm, 28 mm, 22 mm

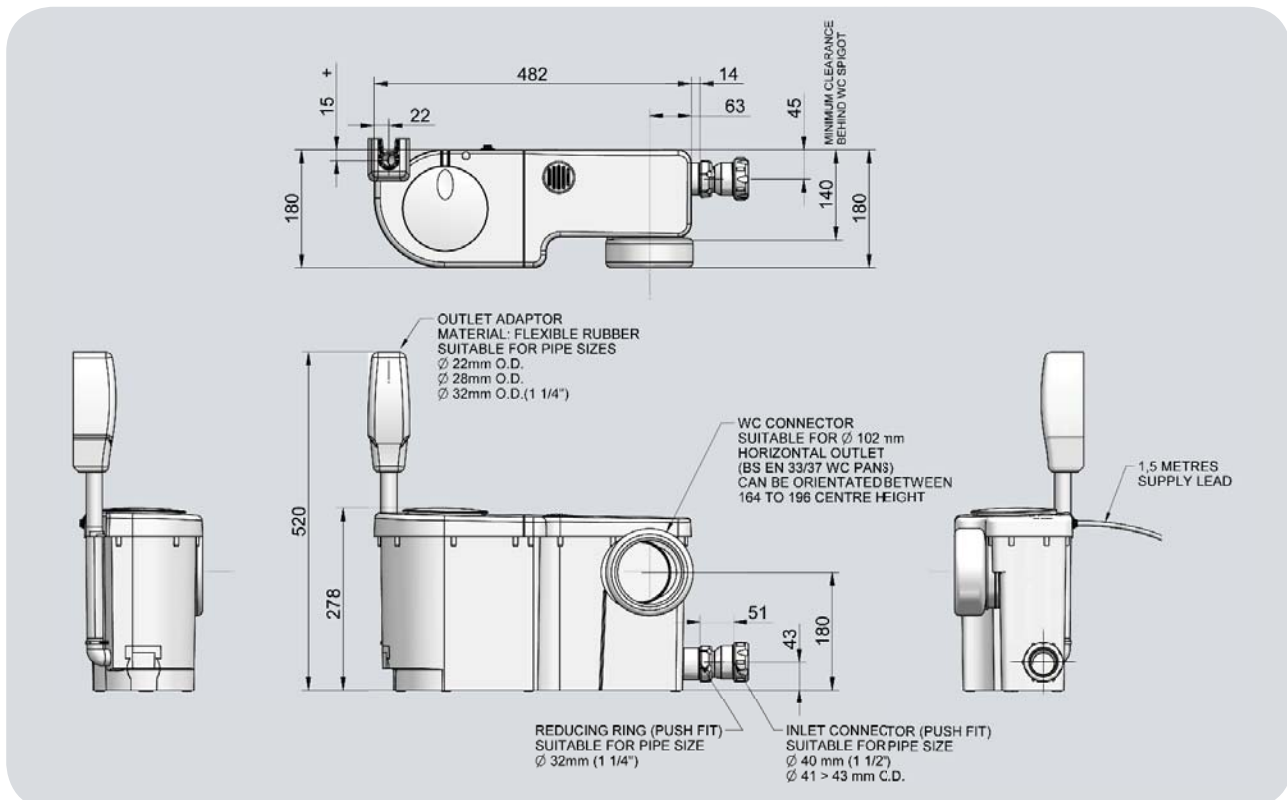

All dimensions shown are in mm.

Stuart Turner Ltd
Henley-on-Thames
Oxfordshire RG9 2AD
England
Telephone: +44 (0)1491 572655
Fax: +44 (0)1491 573704

info@stpumps.co.uk
www.stuart-turner.co.uk

V.A.T. REG. No. 199 0987 92.
Registered in England No. 88368.
Registered Office:
Market Place, Henley-on-Thames

