

# Wasteflo WC3 - Macerator

The Wasteflo WC3 macerator is ideal when transforming any area into a complete bathroom or en-suite. Its attractive and slim design is fully compatible with standard and slimline sanitaryware.

## Application

Macerators are a simple way to pump waste water from a sanitary appliance where there is no local access to a soil pipe.

## Features & Benefits

- Easy to fit.
  - The slimline design of the Wasteflo macerator enables it to fit behind a WC whilst allowing the cistern to be fixed directly to the wall without the use of battens.
  - WC coupling is adjustable to accommodate variations in toilet position and is push-fit. No clips or tools are required.
  - Outlet connection is adjustable to suit a range of waste pipe sizes.
- Easy to maintain.
  - An innovative watertight cassette unit enables easy removal, cleaning and maintenance of the working parts without having to remove the WC, cistern or pipework.

## Specification

- One toilet pan connector with innovative inbuilt height adjustment ( $\pm 16$  mm).
- Two side inlets suitable for 32 mm (1¼") waste pipe to connect to a basin or shower (40 mm (1½") inlet adaptor included).
- Outlet - suitable for 32 mm, 28 mm or 22 mm waste pipe.
- Pumps up to 5 m vertically or 52 m horizontally.
- Maximum flow rate of 90 l/min.
- Complies with BS EN 12050.
- Less than 60 dB noise level.
- Supplied pre-wired with 1.5 m supply cable.
- Full range of spares available.

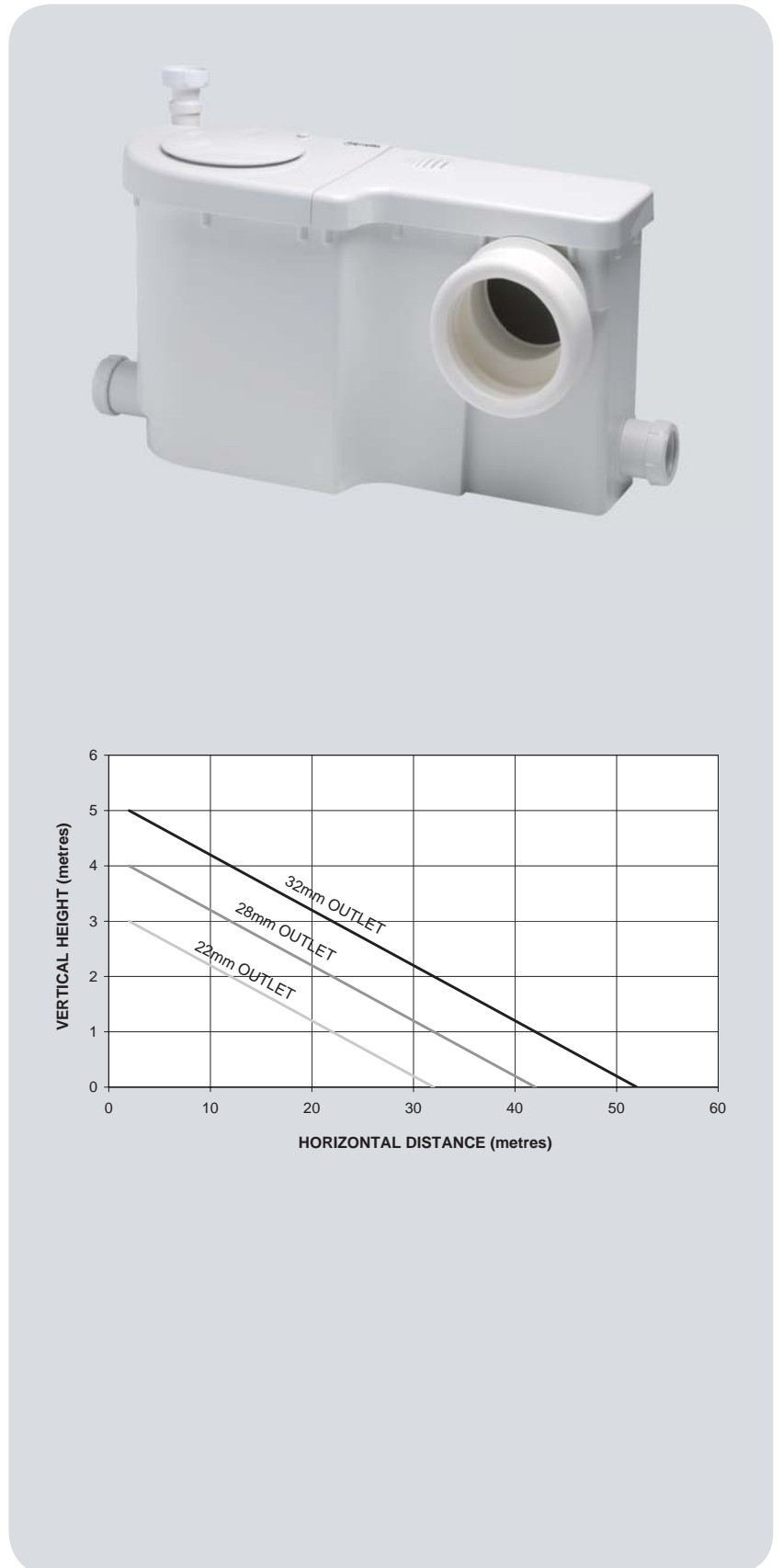

## Wasteflo WC3 - Macerator

Model	Motor	Max. watts consumed	Amps full load	Carton dims. mm			Gross weight (packed) kg	Part no.
				L	W	H		
WC3	230/1/50	500	2.2	580	270	385	9.9	46576

### Materials

Polypropylene, stainless steel, evoprene

### Operating Conditions

Max. liquid temp.	50°C
Min. liquid temp.	4°C
Suction	Flooded
Max. ambient air temp.	40°C

### Pump Connection Sizes

Inlet	32 mm (1¼")
Outlet	32 mm, 28 mm, 22 mm

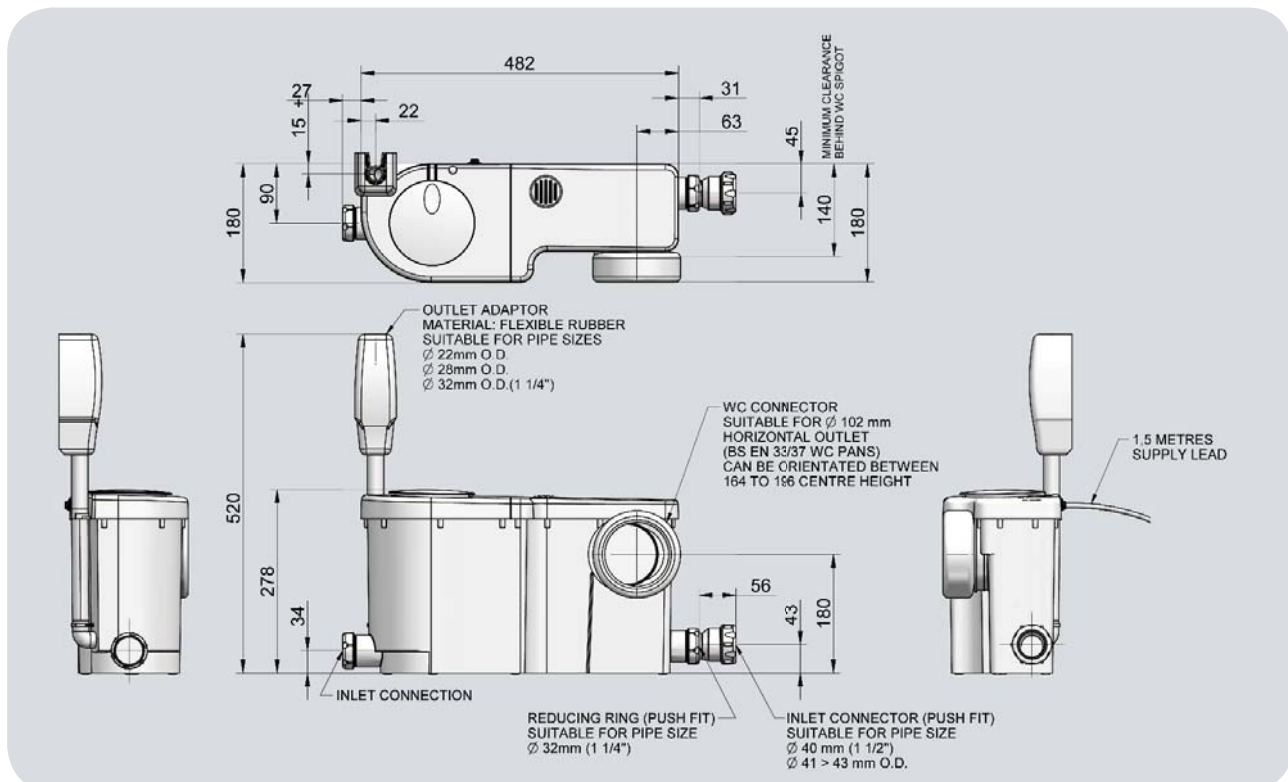

All dimensions shown are in mm.

Stuart Turner Ltd  
Henley-on-Thames  
Oxfordshire RG9 2AD  
England

Telephone: +44 (0)1491 572655  
Fax: +44 (0)1491 573704

info@stpumps.co.uk  
www.stuart-turner.co.uk

V.A.T. REG. No. 199 0987 92.  
Registered in England No. 88368.  
Registered Office:  
Market Place, Henley-on-Thames

