

Performance according to ISO 9906 - Annex A

Power data referred to:

Water [100%]; 277K; 1000kg/m³; 1.57mm²/s

Liquid temperature:

-10°C (14°F) to +110 °C (230°F) for heating pumps

-10°C (14°F) to +85 °C (185°F) for domestic hot water pumps



Pump data

Make	Lowara
Port to port (mm)	180
Electrical connection	Terminals
Specific EEI	<= 0,23
Nominal pressure	PN 6/10
Connection	Threaded pipe / G 2 – Rp 1 ¼

Electrical data

Rated voltage	230 V
Frequency	50
Protection class	IP 44
Insulation class	F
Digital input	Contact load: 5V, 10 mA
Digital output	Vmax < 250 VAC / Imax < 2 A
Analog input	0-10 V / 4-20 mA
Leakage current	< 3.5 mA
Communication capabilities	No communication protocol
Sound pressure level	<= 43 dB(A)

Materials

Bush Bearing	Carbon, resin impregnated	impeller	PPS
Thrust bearing	Aluminum oxide	Wear ring	Stainless steel
Bearing plate	Stainless steel	Rotor can	Stainless steel
Motor housing	Aluminum	Shaft	Stainless steel
O-rings	EPDM	Control box	Poly carbonate
PUMP HOUSING	Cast iron		

Dimensions mm

B1	260
B2	208
B3	52
B4	118
B5	51
C3	116
C4	178
C5	62
Gross weight	10.85
H1	180
H2	67
H3	83
H4	58
L	180
Net weight	7.3

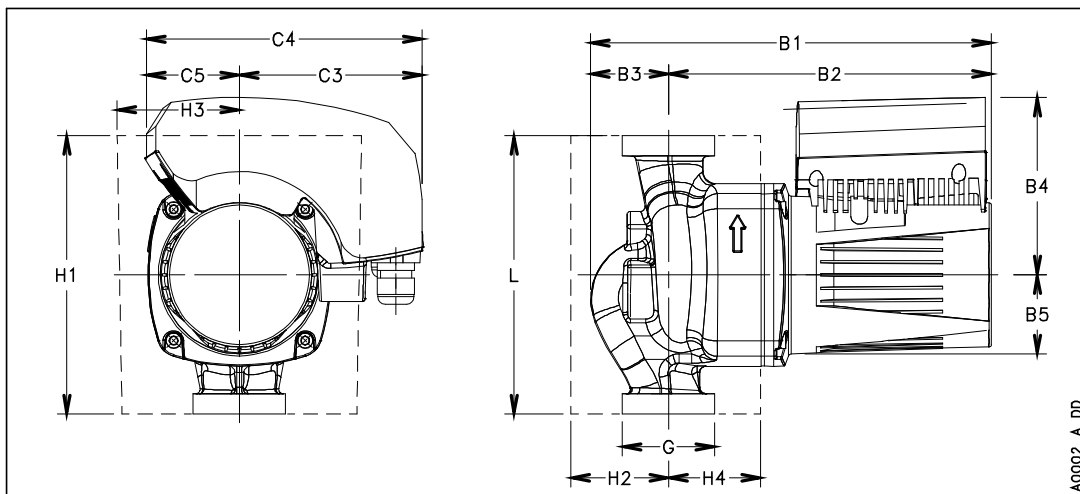

A0002_A_DD