

SHOWERMATE

Universal Single Pump

Showermate Universal Single shower pumps can be used in pairs to pump hot and cold water supplies independently, or as a single pump to boost the hot or cold water supply as required.

High quality, high performance compact pump supplied with two 15 mm anti-vibration flexible hoses with an integral isolation valve on the inlet hose.

All Showermate Universal pumps are suitable for use in open vented (gravity fed) systems for both positive & negative head applications.



Features

- 3 year warranty
- 2.6 bar option
- Suitable for positive or negative head applications
- High quality, high performing plastic pump supplied with 15 mm flexible hoses with an integral ISO valve on the inlet hose
- Quiet operation
- WRAS approved materials
- Continuously rated
- Anti-vibration feet
- EPDM/PTFE/Al. Oxide seal
- Pre-wired with 1.5 metre power cable

Application

- Low pressure gravity systems – boosting hot or cold water supplies to a single shower or to up to four outlets within a bathroom
- Showermate Universal pumps are suitable for use where there is less than 1 litre/min gravity flow from the outlet(s) to be boosted

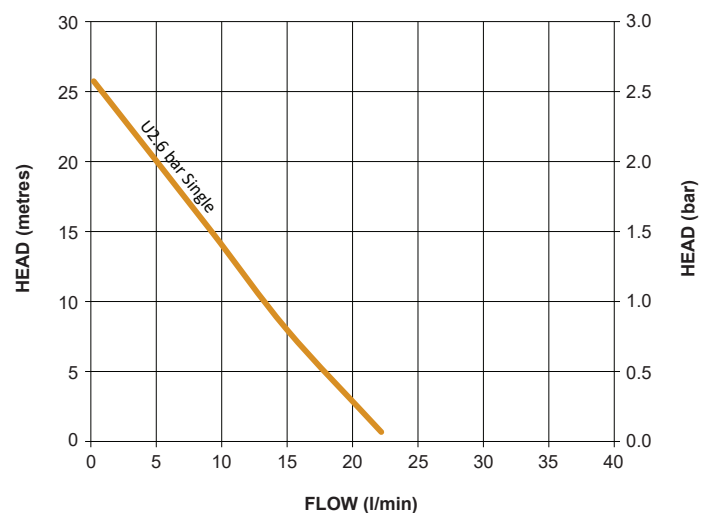

Pump Model		U2.6 bar Single 47375
General	Warranty	3 years
	Approvals	UKCA, CE
Features	Pump type	Peripheral
	Pump control	Pressure & flow switch
	Anti-vibration feet	✓
	Flexible hoses	2
	Run on timer	3 sec
	Dry run protection	✓
	Typical noise	58 dB(A)
Performance	Maximum head – closed valve	2.6 bar (26 metres)
	Performance @ 9 l/min	1.5 bar (15 metres)
	Performance @ 18 l/min	0.5 bar (5 metres)
	Maximum flow	22 l/min
	Maximum static inlet pressure	6 metres
	Maximum static outlet pressure	6 metres
	Maximum working pressure*	400 kPa (4.0 bar)
	Maximum ambient air temperature	40 °C
	Min / Max water temperature**	Min 4 °C / Max 65 °C
	Flow switch sensitivity	0.8 l/min (approx)
	Pressure vessel air pre-charge	1.5 bar (21.75 psi)
Materials	Pump body	Plastic
	Impeller	Plastic
	Mechanical seal	EPDM / PTFE / Al. Oxide
Connections	Pump connections	G ¾ male
Flexible hoses	Connections	G ¾ F x 15 mm push-fit x 200 mm long, isolating valves on inlet hoses
Motor	Type	Induction (auto-reset thermal trip)
	Duty rating	Continuous (S1) @ 9 l/min and above
Electrical	Power supply (Vac/Ph/Hz)	230 V a.c. / 1 / 50 Hz
	Power consumption – P1	310 Watts
	Current – full load	1.4 Amps
	Fuse rating	5 Amps
	Power cable length	1.5 metres (pre-wired to terminal block)
Physical	Enclosure protection	IP22
	Length	251 mm
	Width	154 mm
	Height – excluding hoses	282 mm
	Weight – including fittings	4.7 Kg

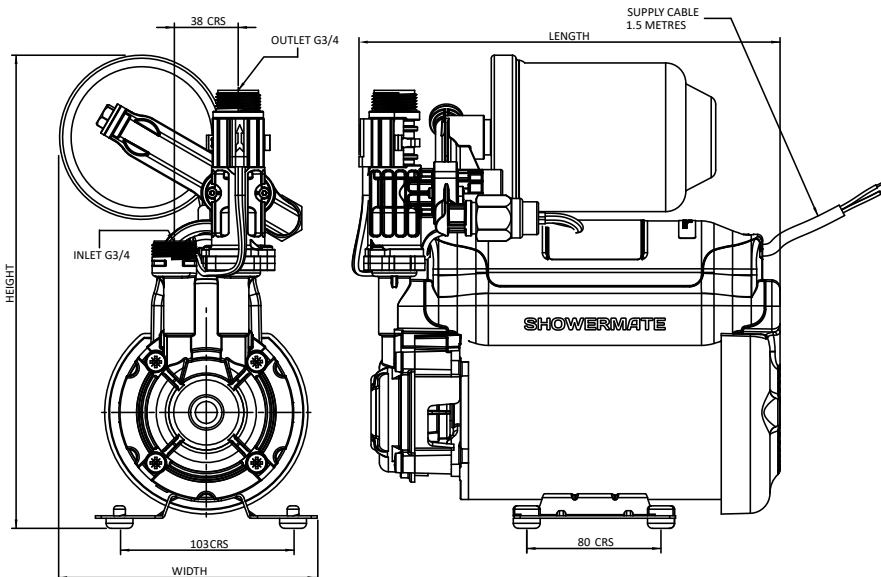

* The maximum pressure that can be applied to the pump under any installation conditions.

** A stored water temperature of 60 °C is considered sufficient to meet all normal requirements and will minimise deposition of scale in hard water areas.

Stuart Turner Limited reserves the right to amend specifications without notice.