

Lifting Station Type ABS Sanimat 1002

SULZER

Flood-proof, double lifting station, for automatic sewage pumping from areas below the backwash level in accordance with EN 12050-1. Ideal for effective dewatering of domestic residences or commercial developments. Suitable for new installations or for renovation of old buildings.

Features

- Plug-in unit with CEE plug and phase sequence changeover facility.
- Easily transported and fitted. Compact dimensions allow passage through a standard door opening.
- Dynamic pressure level sensor on the tank, with separate sensors for inflow level and high water alarm.
- Trouble-free maintenance thanks to simple removal of the motor housing.
- Five horizontal inlet ports (4 x DN 100, 1 x DN 150) and three vertical (2 x DN 100, 1 x DN 150). Vertical vent line DN 70. Two small diameter ports (DN 40/50) suitable only for wastewater. DN 40 is suitable for connection of a hand membrane pump.
- Discharge flange DN 80, plus flanged socket with 4" sleeve and clips (for discharge pipe DN 80/100).
- Direct toilet connection possible in the case of wall-mounted WC units.
- Integrated valve system consisting of two ball-type, non-return valves.
- Two pumps; very quiet thanks to 4-pole, slow-running motors.
- Vortex impeller with large free passage and rear blade mounting, for reliable pumping of both faecal and faecal-free sewage.
- Sloping container floor prevents deposits.
- Built-in mains alarm (visual and acoustic), can be converted to mains-independent by inserting battery.
- Maximum allowable temperature of medium is 40 °C, or up to 60 °C intermittent (max. 5 minutes).

Installation

Attention to the backwash level is of vital importance for effective dewatering. All outflow points located below the backwash level must be protected against back flow according to standard EN 12056.

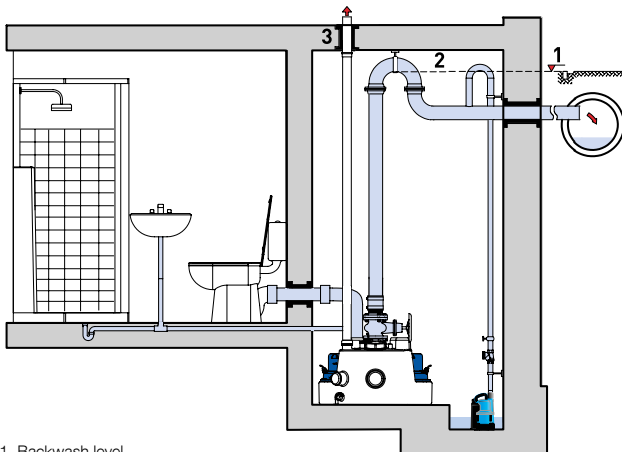

1. Backwash level
2. Backwash loop with base above the backwash level.
3. External ventilation pipe.

Rooms for sewage lifting stations must be large enough that a working area of at least 60 cm width or height is available around all parts which have to be operated or maintained. A pump sump should be provided for dewatering of the room itself.



Tank

Synthetic, corrosion-resistant, gas- and odour-tight tank, in accordance with EN 12050-1. Supplied as standard with pumps, automatic level control and control box, non-return valves, 4" sleeve and flange.

Capacity: 140 litres

Motor

Water pressure sealed, squirrel cage 4-pole induction motor, with triple shaft seals and oil chamber. Electronic monitoring of stator temperature and overcurrent.

Insulation: Class F for 155 °C

Protection type: IP68

Performance curves

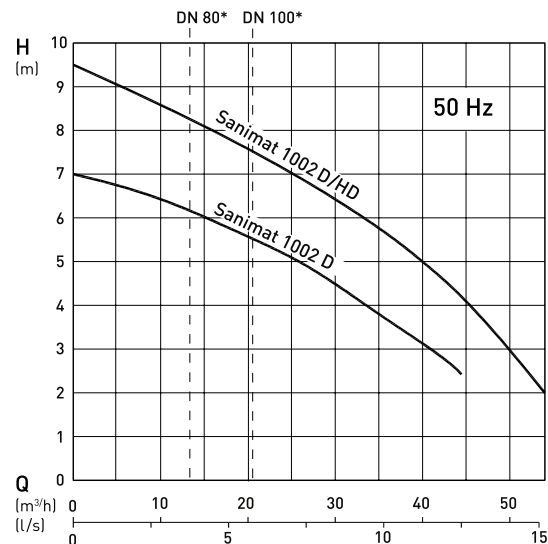

* Minimum flow rate Q for discharge pipe.
H = Total Head; Q = Discharge Volume; Curves to ISO 9906

Materials

Description	Material
Tank	Polyethylene
Motor housing	Cast iron EN-GJL-250
Rotor shaft	Stainless steel 1.4021 (AISI 420)
Volute	Polyethylene
Impeller	Cast iron EN-GJL-250

Technical data

Sanimat	1002 D	1002 D/HD
Discharge connection	Sleeve 4" DN 100	Sleeve 4" DN 100
Motor power [kW]*	$P_1 = 1.77, P_2 = 1.40$	$P_1 = 2.88, P_2 = 2.20$
Speed [r/min]	1450	1450
Rated voltage [V]	400 3~	400 3~
Rated current [A]	3.5	5.2
Cable length [m]**	4 + 1.5	4 + 1.5
Weight [kg]***	115	117

* P_1 = Power taken from mains.

P_2 = Power at motor shaft.

** Tank to control unit 4 m, control unit mains 1.5 m.

*** Additional weight with hand membrane pump = 13 kg

Tank dimensions (mm)

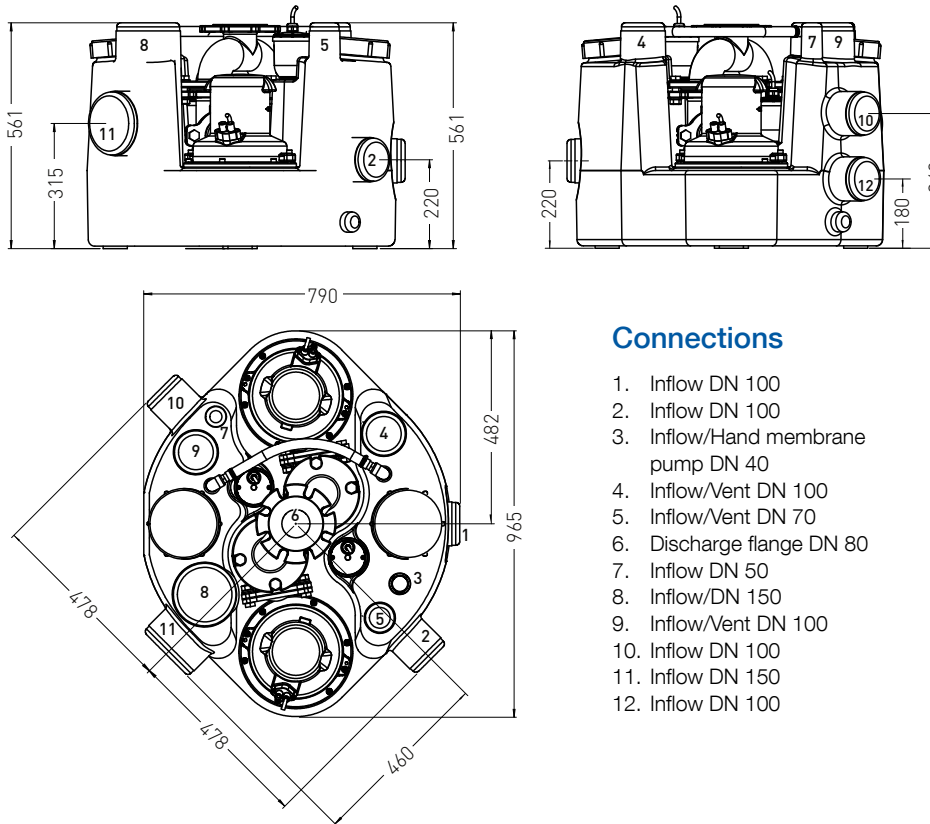

Inlet diameters

Ø	(mm)
DN 70	+0.2 Ø 75 -1.0
DN 100	+0.3 Ø 110 -1.0
DN 150	+0.4 Ø 160 -1.5

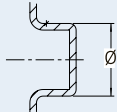

Connections

1. Inflow DN 100
2. Inflow DN 100
3. Inflow/Hand membrane pump DN 40
4. Inflow/Vent DN 100
5. Inflow/Vent DN 70
6. Discharge flange DN 80
7. Inflow DN 50
8. Inflow/DN 150
9. Inflow/Vent DN 100
10. Inflow DN 100
11. Inflow DN 150
12. Inflow DN 100

Accessories

	Description	Size	Part no.
Discharge side	Hand membrane pump with built-in, non-return valve for separate wall fixing.	G 1½"	14990028
	Shut-off valve (EN-GJL-250) including 1 set of bolts and 1 x flat gasket - flange PN 10/16.	DN 80	61420500
	Flanged spigot kit including clamps and flexible connector (1 x DN 80/4" supplied as standard).	DN 80/4"	62540032
Inflow side	PVC double sleeve EN, HTMM	DN 100 DN 150	13760022 13760026
	Flanged sleeve E-KS transition piece DIN-flange/push-on sleeve including 1 x set of bolts and 1 x flat gasket for vertical inflow.	DN 100 DN 150	62540025 62540026
	Shut-off valve (EN-GJL-250) including 1 x set of bolts and 1 x flat gasket - flange PN 10/16.	DN 100 DN 150	61420501 61420503
	NC-AKKU 9 V rechargeable battery for mains-independent alarm.		12820018
Electrical	Extension cable kit one for each pump; consisting of pump- and level-control cables with plugs.	15 m	62665302