

#POWERINGWATER

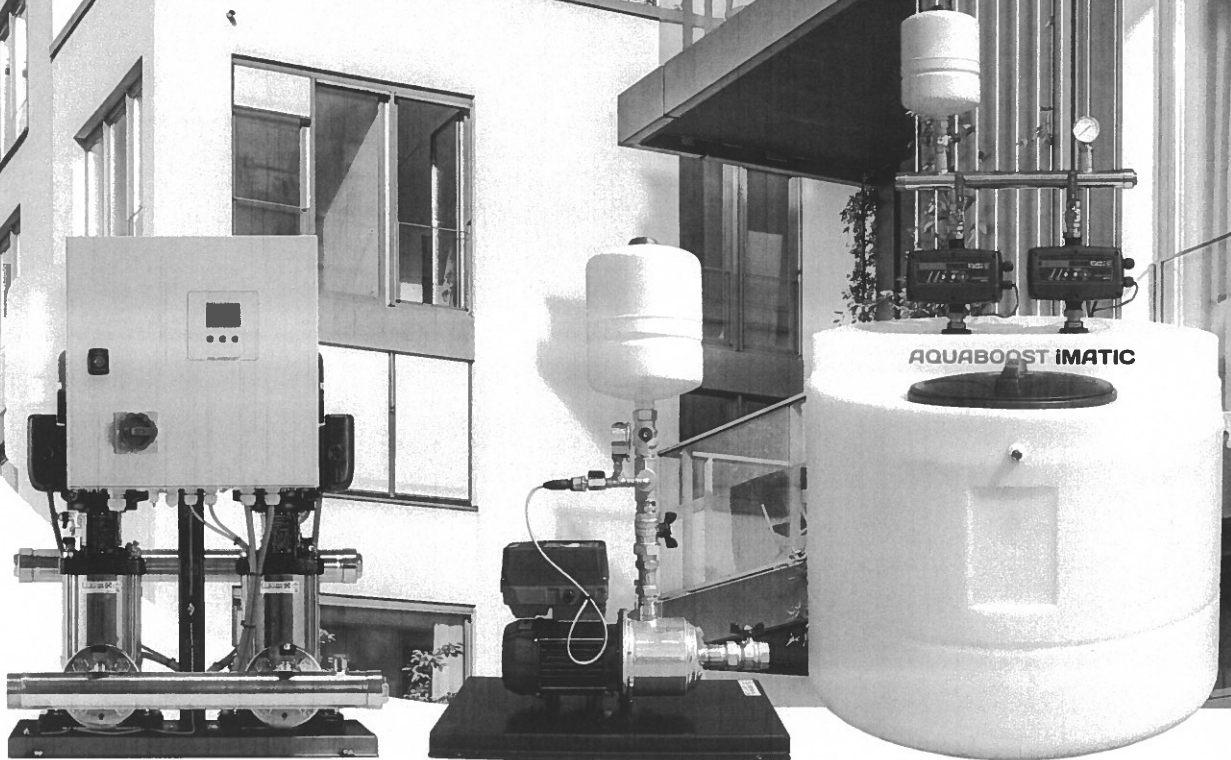

AQUABOOST WATER BOOSTING

STUART-TURNER.CO.UK

**STUART
TURNER** 

ABOUT US

We are a UK manufacturer of pump and water boosting solutions with an unprecedented reputation for product quality, reliability, innovation and customer service.

Customers can expect nothing but the best product, using the latest technology, manufactured to the highest quality standards, resulting in the most reliable solution available.

All our products are designed and manufactured to exacting standards right here in the UK.

Most installations can be satisfied from our standard range of products, however, if you need a more tailored solution, our unique manufacturing facility combined with our technical expertise means we can provide bespoke options specifically aimed at commercial and OEM markets.

Telephone: **TechAssist +44 (0) 800 31 969 80** e-mail info@stuart-turner.co.uk
or visit the support section of the Stuart Turner website to find our specialist in your area.
stuart-turner.co.uk



UNRIVALLED SUPPORT

We are specialists in our field, with a dedicated team able to offer help at every stage.

DESIGN EXPERTISE

Our expert team can conduct a detailed analysis of the performance requirements of the intended project to produce a fully costed proposal. All our systems are custom designed in-house using the latest CAD software to develop, evaluate and aid the design of the most efficient solution for your specific needs.



COMMISSIONING

We provide a full commissioning service on all our systems and are available to advise on the installation of your system should you require our technical help or practical expertise.



MANUFACTURING EXCELLENCE

We have invested in the latest production and manufacturing technologies to ensure we work to the highest quality standards. This guarantees our system reliability whilst at the same time minimising costs, improving efficiency and delivering on time and in full.

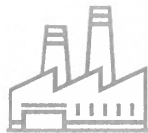

MAINTENANCE

Ongoing maintenance is a cost-effective solution to prolonging the life of your system and maximising its operational efficiency. To ensure the system continues to operate effectively and reliably we can also offer a comprehensive maintenance and service contract.



TECHNICAL TRAINING

We offer a range of CPD courses aimed at building service engineers and accredited by CIBSE – Chartered Institution of Building Service Engineers. CIBSE is an internationally recognised

whose membership is available to all building service engineers through training and education.

Visit the **CIBSE** website for further details.



ON-GOING SUPPORT

The quality and reliability of our products and services are second to none, allowing you peace of mind when you specify Stuart Turner. However, should you experience any issues we have a

dedicated service to guarantee a speedy response to product selection.

Technical helpline:
TechAssist 0800 31 969 80



INTRODUCING

AQUABOOST BOOSTER SETS

LOW PRESSURE? NO PROBLEM!

Aquaboost offers the ultimate water supply solution.

We offer a comprehensive range of standard water boosting sets, designed to optimise space and provide a very quiet, simple to install package for both large domestic and commercial applications.

If one of our standard solutions does not meet your needs then Aquaboost bespoke packaged pump systems are

Aquaboost cold water pressure and flow boosting solutions utilise high quality pumps combined with intelligent variable speed controls to solve the problem of poor water pressure in multiple applications.

Simple to commission and ready to go!

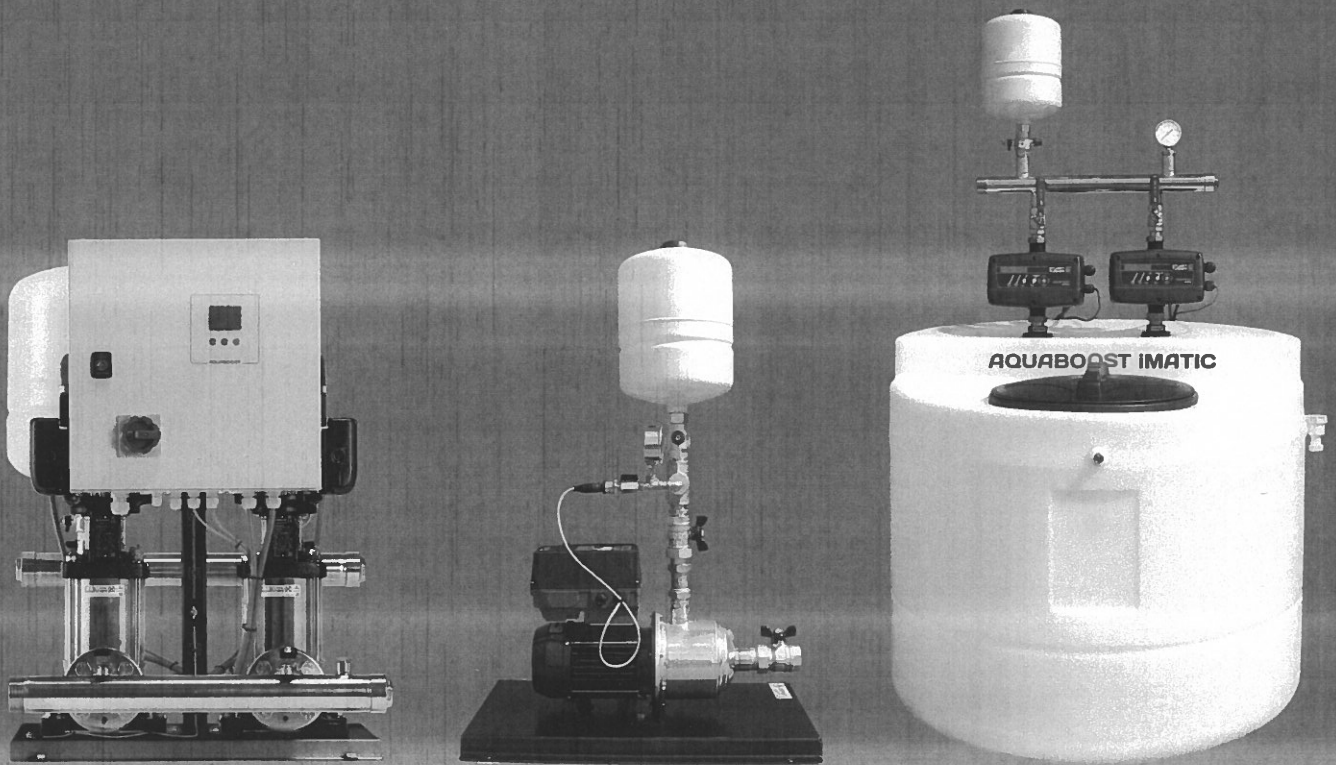

"Stuart Turner offer a range of *Aquaboost* booster sets and integrated pump and water storage systems, designed to optimise space, provide higher water pressure and flow to multiple outlets and supplied as a ready to install fully packaged product."

INTRODUCING

AQUABOOST

iBOLT

- ▶ UP TO 9.2 BAR PRESSURE
- ▶ FLOW RATES UP TO 16 M³/ HOUR
- ▶ ADVANCED VARIABLE SPEED CONTROL
- ▶ 8 or 24 LITRE PRESSURE VESSEL OPTIONS
- ▶ DRY RUN PROTECTION

Available as a stand-alone single pump or single and twin booster sets. The Aquaboost iBolt range of variable speed booster pumps and pump sets feature horizontal multistage pumps controlled by air-cooled variable speed frequency inverters mounted directly on the pump motor. Designed to be a high performing and intuitive to commission pump range, offering constant water pressure supply where flow demand varies.

GOOD TO KNOW

Aquaboost iBolt pump and booster sets feature WRAS approved lever ball valves and BMS volt free contacts and utilise variable speed controllers, which continually vary the motor speed to match the changing flow demand pattern, whilst maintaining a

DID YOU KNOW

Aquaboost iBolt booster sets are available with a WRAS approved 8 or 24 litre pressure vessel, providing an added buffer of pressurised cold water to supplement pressure and flow.

WRAS APPROVED PRESSURE VESSEL

ADVANCED PUMP CONTROL

HIGH QUALITY MULTISTAGE PUMP

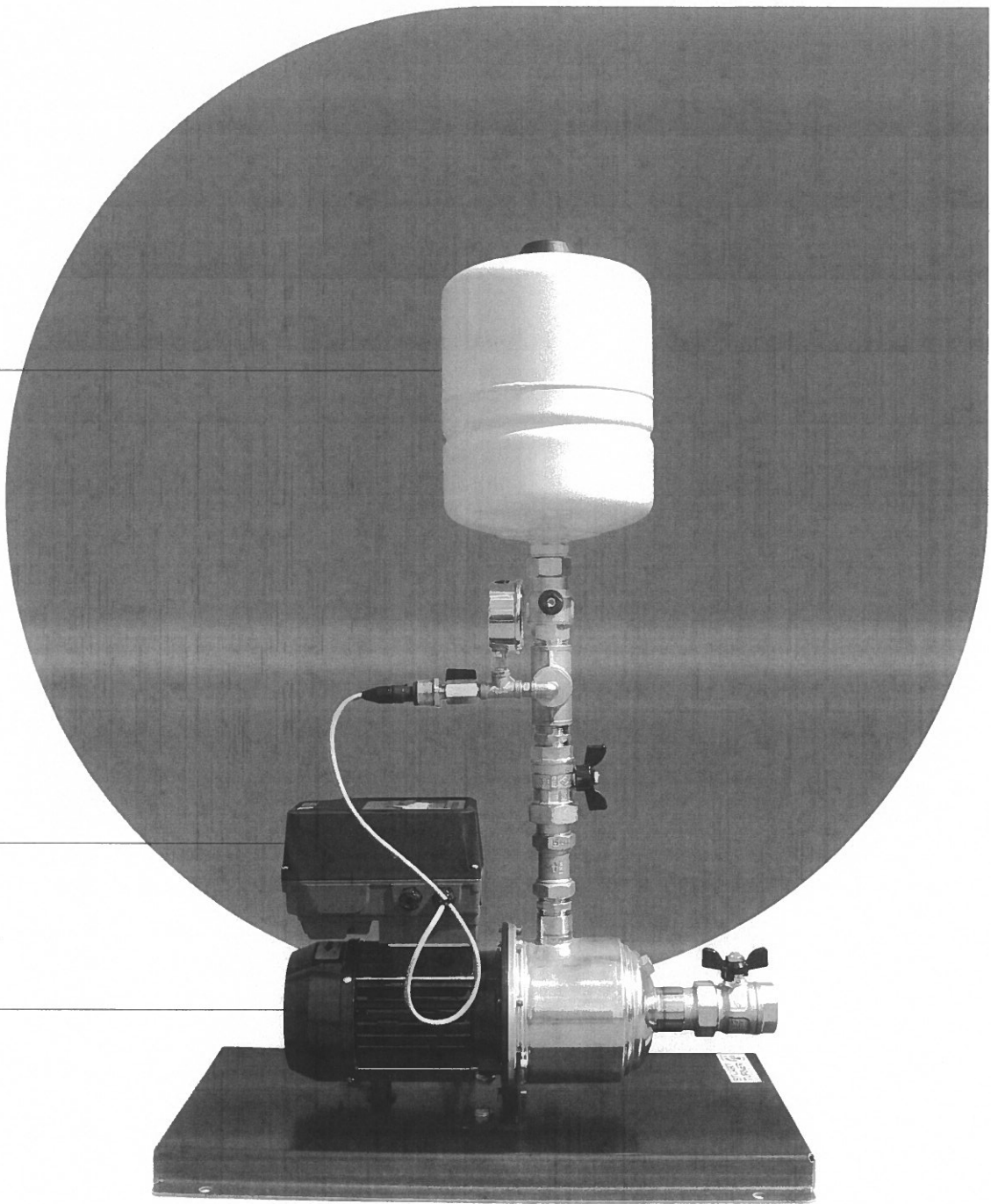

Product Code Structure Example:

iBOLT 0904 2H CMT / 24



AQUABOOST iBOLT

iBolt Single Pumps

The Aquaboost iBolt range of booster pumps features a horizontal multistage pump controlled by an air-cooled variable speed frequency inverter mounted directly on the pump motor.

The single pump 03 range of pump variants are capable of delivering flow rates up to 5.0 m³/hour and producing head pressures of up to 9.0 bar.

The 05 range of pump variants deliver flow rates up to 8.0 m³/hour and are capable of producing head pressures of up to 9.2 bar.

The 09 range of pump variants are capable of delivering flow rates up to 15.0 m³/hour and of producing head pressures of up to 7.1 bar.

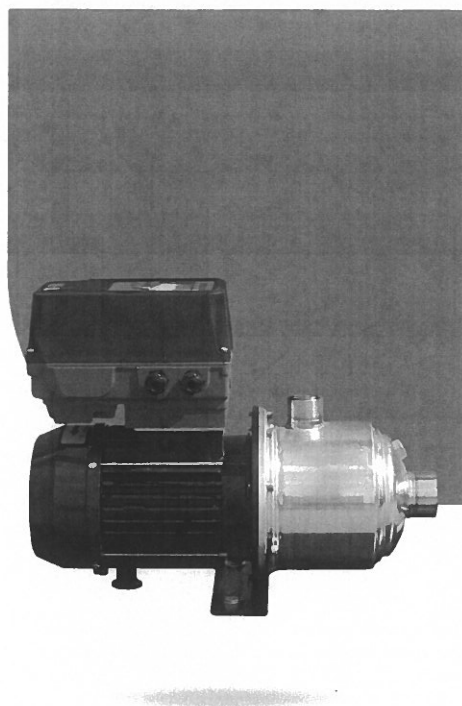

▶ UP TO 9.2 BAR PRESSURE

▶ ADVANCED VARIABLE SPEED CONTROL

▶ FLOW RATES UP TO 15 M³/ HOUR

▶ DRY RUN PROTECTION

Part No	Model	Nominal Flow (per pump) (m ³ /hr)	Nominal Head (bar)
47345	iBolt Pump 0304	3	3.0
47346	iBolt Pump 0306	3	4.7
47348	iBolt Pump 0506	5	5.0
47347	iBolt Pump 0504	5	3.4
47348	iBolt Pump 0506	5	5.0
47349	iBolt Pump 0904	9	3.6
47350	iBolt Pump 0906	9	5.0

TECHNICAL SPECIFICATIONS

		iBolt Pump 0304 47345	iBolt Pump 0506 47348	iBolt Pump 0906 47350
General	Warranty	2 Years		
	Conformity certification	UKCA / CE		
Features	Pump control system	Variable speed (via pressure transducer)		
	Pump control mode	Duty		
	Dry run protection	•	•	•
	BMS volt-free contacts	•	•	•
Performance	Nominal head	3.0 bar	5.0 bar	5.0 bar
	Maximum head (closed valve)	4.4 bar	7.0 bar	7.1 bar
	Nominal flow rate	3.0 m ³ /h	5.0 m ³ /h	9.0 m ³ /h
	Maximum flow rate	5.0 m ³ /h	8.0 m ³ /h	15.0 m ³ /h
	Minimum static inlet pressure	0.1 bar		
	Maximum static inlet pressure	1 bar		
	Maximum static outlet pressure	1.3 bar		
	Maximum air temperature	40 °C		
Connections	Inlet	1 3/4"		
	Outlet	1"		
Pump	Pump type	Centrifugal multistage		
	Pump body	Stainless steel		
	Impeller	Stainless steel		
	Mechanical seal	EPDM / Carbon / Ceramic		
	Motor type	Induction (current overload sensor)		
	Duty rating	Continuous		
Electrical	Voltage / phase / frequency	230 V a.c. / 1 / 50 Hz		
	Current – full load	2.9 Amps	5.5 Amps	8.7 Amps
Physical	Enclosure protection	IP55		
	Width	176.5 mm	176.5 mm	176.5 mm
	Depth	387 mm	472 mm	556 mm
	Height	300 mm	315 mm	320 mm
	Weight	13 Kg	18 Kg	25 Kg

The above details are published for guidance only. Please visit the Stuart Turner website for the full technical specifications: stuart-turner.co.uk

AQUABOOST iBOLT

iBolt Single Pump Booster Set

The Aquaboost iBolt range of single pump booster sets features a horizontal multistage pump controlled by an air-cooled variable speed frequency inverter mounted directly on the pump motor.

The 03 single pump booster set range are capable of delivering flow rates up to 5.0 m³/hour and head pressures of up to 9.0 bar.

The 05 single pump booster set variants deliver flow rates up to 8.0 m³/hour and capable of producing head pressures of up to 9.2 bar.

The 09 range of single pump booster sets offer an impressive 15.0 m³/hour flow rate and are capable of producing head pressures of up to 7.1 bar depending on the chosen variant.

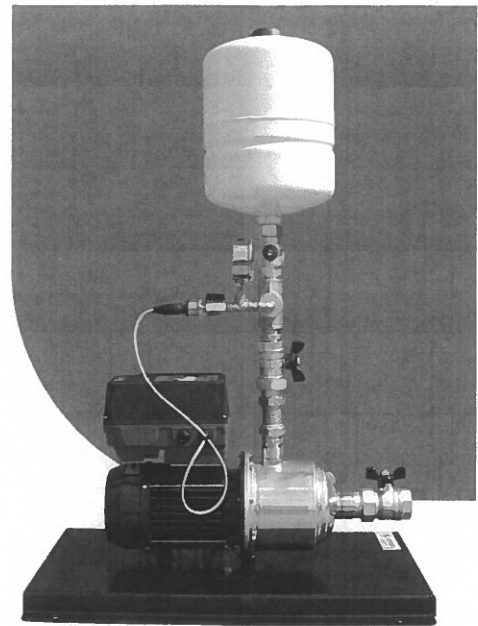

- ▶ UP TO 9.2 BAR PRESSURE
- ▶ FLOW RATES UP TO 15 M³/ HOUR
- ▶ ADVANCED VARIABLE SPEED CONTROL
- ▶ DRY RUN PROTECTION
- ▶ WRAS APPROVED 8 LITRE PRESSURE VESSEL

Part No	Model	Nominal Flow (per pump) (m ³ /hr)	Nominal Head (bar)
47381	iBolt 0304 1H-CMT/8	3	3.0
47382	iBolt 0306 1H-CMT/8	3	4.7
47383	iBolt 0308 1H-CMT/8	3	6.4
47384	iBolt 0504 1H-CMT/8	5	3.4
47385	iBolt 0506 1H-CMT/8	5	5.0
47386	iBolt 0508 1H-CMT/8	5	6.7
47387	iBolt 0904 1H-CMT/8	9	3.6
47389	iBolt 0906 1H-CMT/8	9	5.0

TECHNICAL SPECIFICATIONS

		iBolt 0304 1H-CMT/8 47381	iBolt 0504 1H-CMT/8 47384	iBolt 0906 1H-CMT/8 47389
General	Warranty	2 Years		
	Conformity certification	UKCA / CE		
Features	Pump control system	Variable speed (via pressure transducer)		
	Pump control mode	Duty		
	Dry run protection	•	•	•
	Glycerine filled pressure gauge	•	•	•
	Pump check valve(s)	•	•	•
	BMS volt-free contacts	•	•	•
	Pressure vessel	8Litres		
Performance	Nominal head	3.0 bar	3.4 bar	5.0 bar
	Maximum head (closed valve)	4.4 bar	4.6 bar	7.1 bar
	Nominal flow rate	3.0 m ³ /h	5.0 m ³ /h	9.0 m ³ /h
	Maximum flow rate	5.0 m ³ /h	8.0 m ³ /h	15.0 m ³ /h
	Minimum static inlet pressure	0.1 bar		
	Maximum static inlet pressure	1 bar		
	Maximum static outlet pressure	1.3 bar		
	Maximum air temperature	40 °C		
Connections	Inlet	1 1/4"	1 1/4"	1 1/2"
	Outlet	1"	1"	1 1/4"
Manifold	Manifold construction	Stainless steel		
	Pump isolation valves	Full bore, lever		
Pump	Pump type	Centrifugal multistage		
	Pump body	Stainless steel		
	Impeller	Stainless steel		
	Mechanical seal	EPDM / Carbon / Ceramic		
	Motor type	Induction (current overload sensor)		
	Duty rating	Continuous		
Electrical	voltage / phase / frequency	230 V a.c. / 1 / 50 Hz		
	Current - full load	2.9 Amps	3.7 Amps	8.7 Amps
Physical	Enclosure protection	IP65		
	Depth	560 mm	570 mm	570 mm
	Height	840 mm	840 mm	840 mm
	Weight	24Kg	29 Kg	36 Kg

The above details are published for guidance only. Please visit the Stuart Turner website for the full technical specifications: stuart-turner.co.uk

AQUABOOST iBOLT

iBolt Twin Pump Booster Set

The Aquaboost iBolt range of twin pump booster sets features two horizontal multistage pumps controlled by air-cooled variable speed frequency inverters mounted directly on the pump motors.

The twin pump booster set 03 range of pump variants are capable of delivering flow rates up to 5.0 m³/hour (per pump) and capable of producing head pressures of up to 9.0 bar.

The twin pump booster set 05 range are capable of delivering flow rates up to 8.0 m³/hour (per pump) and of producing head pressures of up to 9.2 bar.

The twin pump booster set 09 range are capable of delivering flow rates up to 30.0 m³/hour (per pump) and of producing head pressures of up to 9.2 bar.



- ▶ UP TO 9.2 BAR PRESSURE
- ▶ FLOW RATES UP TO 30 M³/ HOUR
- ▶ ADVANCED VARIABLE SPEED CONTROL
- ▶ DRY RUN PROTECTION
- ▶ WRAS APPROVED 24 LITRE PRESSURE VESSEL

Part No	Model	Nominal Flow (per pump) (m ³ /hr)	Nominal Head (bar)
47353	iBolt 0304 2H-CMT/24	3	3
47354	iBolt 0306 2H-CMT/24	3	3
47355	iBolt 0504 2H-CMT/24	5	5
47356	iBolt 0506 2H-CMT/24	5	5
47357	iBolt 0904 2H-CMT/24	9	9
47358	iBolt 0906 2H-CMT/24	9	9

TECHNICAL SPECIFICATIONS

		iBolt 0304 2H-CMT/24 47353	iBolt 0506 2H-CMT/24 47356	iBolt 0906 2H-CMT/24 47358
General	Warranty	2 Years		
	Conformity certification	UKCA/CE		
Features	Pump control system	Variable speed (via pressure transducer)		
	Pump control mode	Duty / Standby or Duty / Assist		
	Dry run protection	•	•	•
	Glycerine filled pressure gauge	•	•	•
	Pump check valve(s)	•	•	•
	BMS volt-free contacts	•	•	•
	Pressure vessel	24 Litres		
Performance	Nominal head	3.0 bar	5.0 bar	5.0 bar
	Maximum head (closed valve)	4.4bar	7.0 bar	7.1 bar
	Nominal flow rate (per pump)	6.0 m ³ /h (9.0 m ³ h)	10.0 m ³ /h (9.0 m ³ h)	18.0 m ³ /h (9.0 m ³ h)
	Maximum flow rate (per pump)	10 m ³ /h (5.0 m ³ h)	16.0 m ³ /h (8.0 m ³ h)	30.0 m ³ /h (15.0 m ³ h)
	Minimum static inlet pressure	0.1 bar		
	Maximum static inlet pressure	1 bar		
	Maximum static outlet pressure	1.3 bar		
	Maximum air temperature	40 °C		
Connections	Inlet	2"	2"	2 ½"
	Outlet	1 ½"	1 ½"	2"
Manifold	Manifold construction	Stainless steel		
	Pump isolation valves	Full bore, lever, WRAS Approved		
Pump	Pump type	Centrifugal multistage		
	Pump body	Stainless steel		
	Impeller	Stainless steel		
	Mechanical seal	EPDM / Carbon / Ceramic		
	Motor type	Induction (current overload sensor)		
	Duty rating	Continuous		
Electrical	Voltage / phase / frequency	230 V a.c. / 1 / 50 Hz		
	Current - full load	5.8 Amps	11.0 Amps	17.4 Amps
Physical	Enclosure protection	IP55		
	Depth	490 mm	500 mm	500 mm
	Height	1050 mm	1050 mm	1085 mm
	Weight	49 Kg	59 Kg	68 Kg

The above details are published for guidance only. Please visit the Stuart Turner website for the full technical specifications: stuart-turner.co.uk