



Submersible Motor Pumps 50 Hz

Fields of Application

Ama[®]–Porter pumps are used for handling all types of dirty liquids, e.g.:

Handling waste water containing long fibres and solid substances as well as media containing gas/air.

Drainage/water extraction; drainage of rooms and surfaces subject to a flooding risk on municipal, industrial and commercial premises.

Operating Data

Q : up to 40 m³/h, 11 l/s

H up to 16 m

Motor rating:

1.5 kW max. with three-phase motor

1.1 kW max. with single-phase a.c. motor

Product temperature up to 40° C.

For short periods 70°C (3 to 5 min).

Mode of operation: intermittent operation S3

Materials

Casing : Cast iron GG 20 / EN.GJL-200 / JL 1030 / FGL 200.

Impeller : Cast iron GG 20 / EN.GJL-200 / JL 1030 / FGL 200.

Shaft : 1.4021 / X20 Cr13 / Z20 C13.

Shaft seal (drive end): lip seal

Shaft seal (pump end): mechanical seal SiC / Al₂O₃

Bolts and nuts : A2

Joint rings : nitrile rubber

ICS: polypropylene

Innovation

The Intelligent Control System ICS[®] ensures automatic operation of the pump(s) without floats and control panels.

Designation

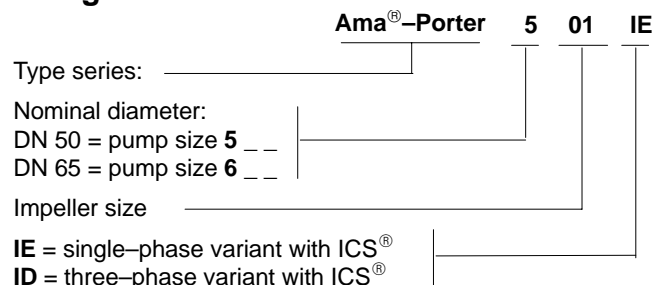

Design

Vertical submersible motor pump in close-coupled design.

Shaft Seal

Drive end: : 1 shaft seal ring

Pump end: : 1 bi-rotational mechanical seal
with environment-friendly oil fill

Motor

Single-phase a.c. motor
230 V, max. 255 V – 50 Hz
with integrated overload protection.

Three-phase asynchronous motor
400 V, max. 440 V – 50 Hz,
d.o.l. starting; with integrated overload protection.

Motors IP 68, thermal class F to EN 60529 / IEC 529.

Bearings

Grease-lubricated ball bearings sealed for life.

CE – EN 12 050-1

The pump must not be used in countries where pumps handling sewage with faeces are subject to explosion protection regulations.

Scope of Supply

Complete unit as portable version or for stationary installation consisting of pump set and installation kit.

Thermal Overload Protection of the Motors

Single-phase a.c.

Winding is protected by 1 temperature switch at 160° C

Three-phase asynchronous motor

Winding is protected by 2 temperature switches 160 °C as a standard.

Pump Set

- Material: Cast iron GG 20 / EN.GJL-200 / JL 1030 / FGL 200.
- Non-explosion-proof motor.
- Absolutely water-tight, resin-embedded cable entry.
- Single-phase a.c. motor, 10 m cable with 3 pin plug to EU standards.
- Three-phase asynchronous motor, 10 m cable.
- Installation parts
- Protective coating:
 - Surface treatment: SA 2 1/2 SIS 055900
 - Primer coat: ferritic oxide 35 to 40 µm.
 - Top coat: 1 environment-friendly KSB standard coat 40 µm – RAL 5002.

PLEASE NOTE: A SWING CHECK VALVE MUST ABSOLUTELY BE INSTALLED IN THE DISCHARGE LINE.

Installation Kit

Pump size	5 -- IE/ID	6 -- IE/ID
Variant		
Portable	3 support feet, made of stainless steel 1.4301 Connection elbow with internal thread 2" Adapter 2"/63 mm Hose clip (∅ 60 to 80) Bolts and nuts	3 support feet, made of stainless steel 1.4301 Connection elbow with internal thread 2 1/2" Adapter 2 1/2" /80 mm Hose clip (∅ 80 to 100) Bolts and nuts
Stationary Guide rope or rail or hoop (vertical discharge connection)	Duckfoot bend 50/50 mm Claw Bracket Guiding rope or hoop Rail not included Anchor bolts Chain	Duckfoot bend 65/65 mm Claw Bracket Guiding rope or hoop Rail not included Anchor bolts Chain
Stationary Guide rope or rail or hoop (horizontal discharge connection)	Duckfoot bend 50/2" Claw Bracket Guiding rope or hoop Rail not included Anchor bolts Chain	Duckfoot bend 65/2 1/2" Claw Bracket Guiding rope or hoop Rail not included Anchor bolts Chain

Automatic Pump Control by ICS[®]

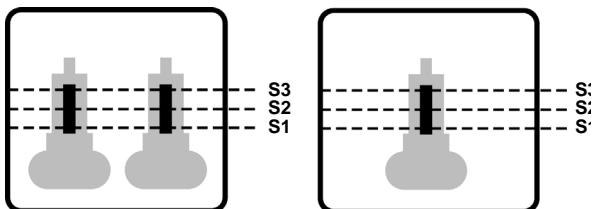

First pumping cycle

As soon as level S2 is reached for the first time, both pumps start and operate until the tank has been emptied.

At the same time, each pump is assigned a cut-in delay period for the next start-up.

When the pumps stop, ICS[®] measures the pumping time required and calculates the pumping time for the the next cycle.

Second pumping cycle

Once level S2 is reached again, the pump with the shorter cut-in delay period is started.

Via its ICS[®], the pump not in operation recognises that the other pump is in operation and cancels its own cut-in delay period.

The pump in operation stops after expiry of its calculated operating period and is assigned another cut-in delay period.

Consecutive pumping cycles

For the subsequent pumping cycles, ICS[®] controls changeover between the two pumps.

Every eight cycles, ICS[®] recalculates the parameters and assigns each pump an updated operating time so as to optimise operation of the pumping station.

Parallel operation

If the flow into the tank exceeds the discharge capacity of a single pump, and level S3 is reached, ICS[®] starts up the second pump without delay.

The second pump is also started up if the water level remains at level S2 for a prolonged period of time.

Both pumps continue to operate until the tank has been emptied.

Prolonged standstill of the unit

24 hours after the last pump operation, ICS[®] automatically starts up each pump. If any waste water is present, pumping will continue until the tank has been emptied. Otherwise, pump operation will stop again in a fraction of a second.

This way ICS[®] eliminates the risk of clogging and reduces bad odours to a minimum.

Ama[®]-Porter Product Features

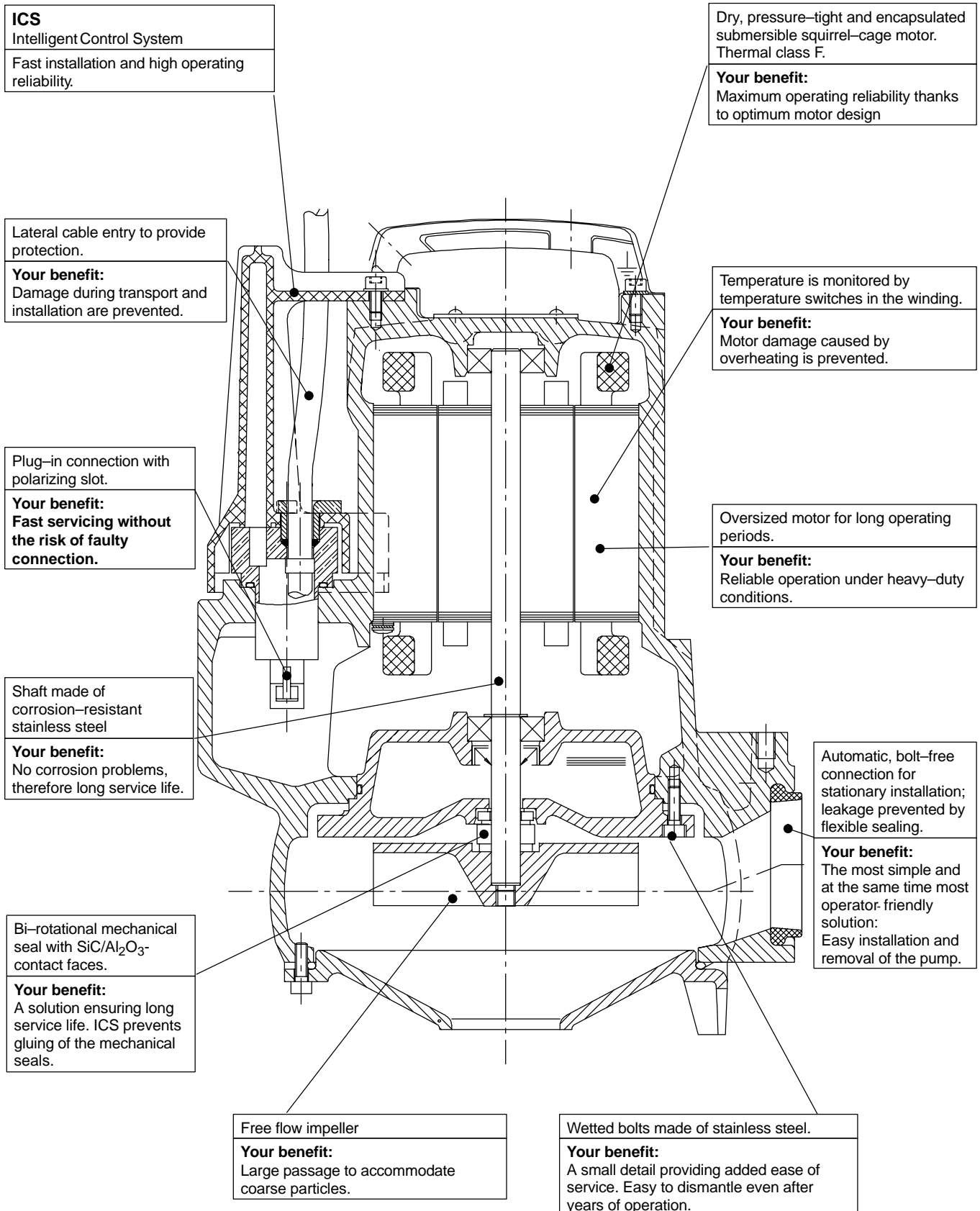

Ama®-Porter Size 5 -- IE/ID

2900 1/min

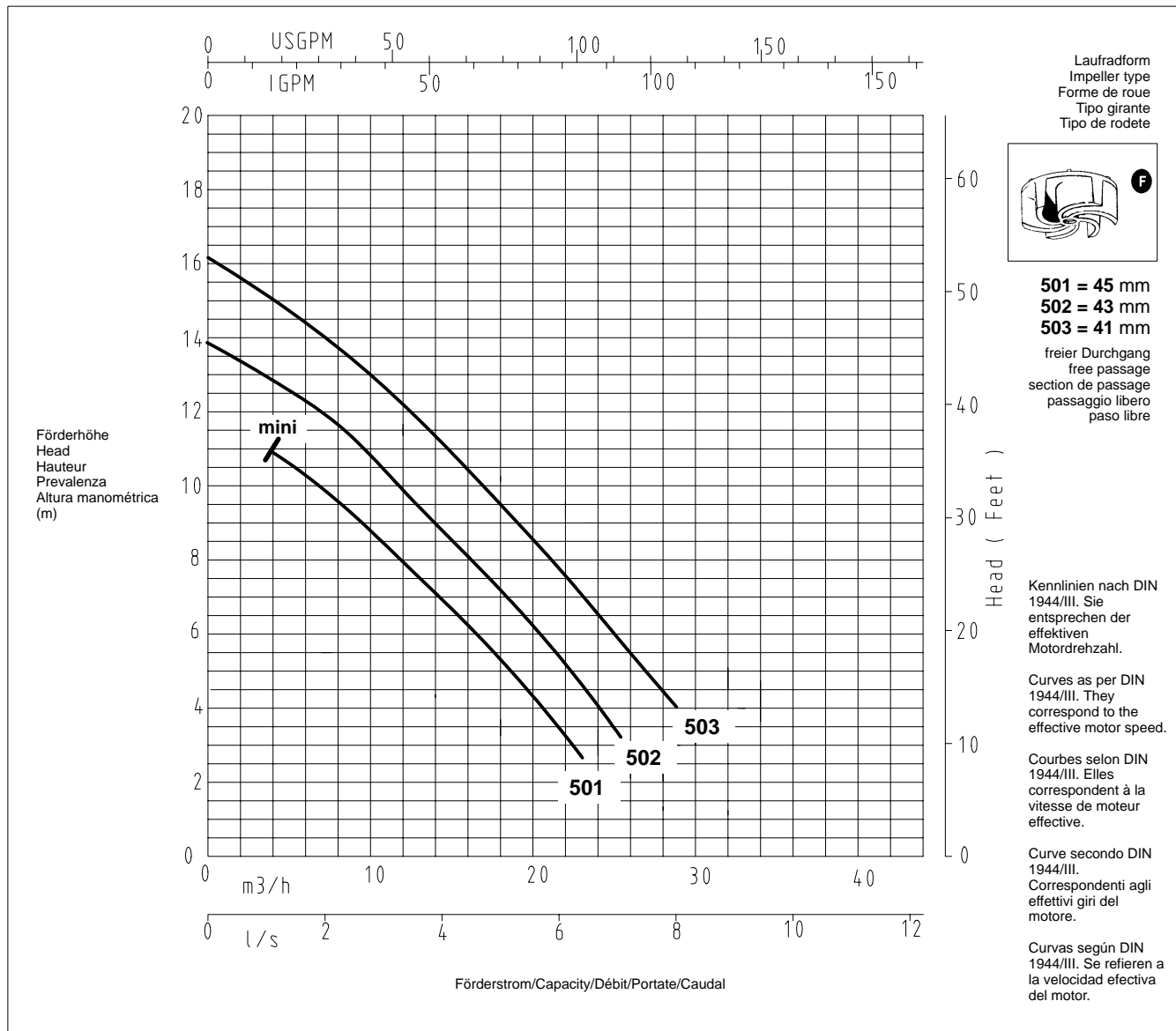

50 Hz – 1~ 230 V

Pump size	Impeller-Ø mm	P ₁ kW	P ₂ kW	I _N (A)	I _A (A)	Product temp. °C	Power supply cable	Power supply cable outside diameter mm	Weight kg	Ident. No.
501 IE	110	1,25	0,75	6,0	18,2	40	3 x 1 mm ²	9,0	22	39 020 142
502 IE	120	1,8	1,1	8,2	18,2	40	3 x 1 mm ²	9,0	22	39 020 143
503 IE	130	1,8	1,1	8,2	18,2	40	3 x 1 mm ²	9,0	22	39 020 144

50 Hz – 3~ 400 V

501 ID	110	1,1	0,75	2,8	18,3	40	4 x 1 mm ²	10	22	39 020 150
502 ID	120	1,5	1,1	3,0	18,3	40	4 x 1 mm ²	10	22	39 020 151
503 ID	130	2,05	1,5	3,5	18,3	40	4 x 1 mm ²	10	22	39 020 152

γ=1 kg/dm³, Viscosity=1 cSt.

Ama[®]-Porter Size 6 – – IE/ID

2900 1/min

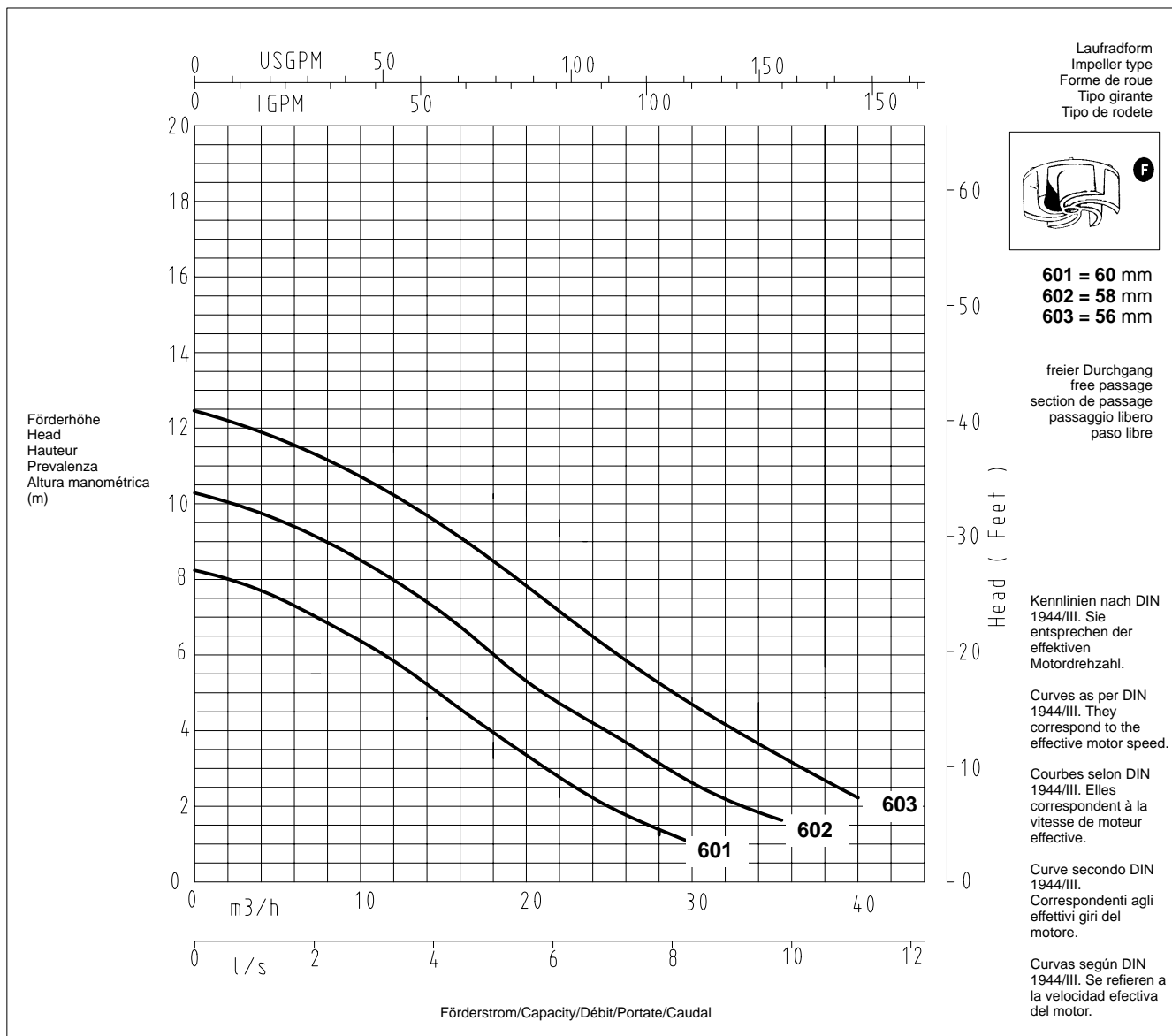

50 Hz – 1~ 230 V

Pump size	Impeller-Ø	P ₁	P ₂	I _N	I _A	Product temp.	Power supply cable	Power supply cable outside diameter	Weight	Ident. No.
	mm	kW	kW	(A)	(A)	°C		mm	kg	
601 IE	110	1,25	0,75	6,0	18,2	40	3 x 1 mm ²	9,0	25	39 020 153
602 IE	120	1,8	1,1	8,2	18,2	40	3 x 1 mm ²	9,0	25	39 020 154
603 IE	130	1,8	1,1	8,2	18,2	40	3 x 1 mm ²	9,0	25	39 020 155

50 Hz – 3~ 400 V

601 ID	110	1,1	0,75	2,8	18,3	40	4 x 1 mm ²	10	25	39 020 159
602 ID	120	1,5	1,1	3,0	18,3	40	4 x 1 mm ²	10	25	39 020 160
603 ID	130	2,05	1,5	3,5	18,3	40	4 x 1 mm ²	10	25	39 020 161

γ=1 kg/dm³, Viscosity=1 cSt.

Dimensions

Ama[®]-Porter ICS[®] série 5 --

Transportable version

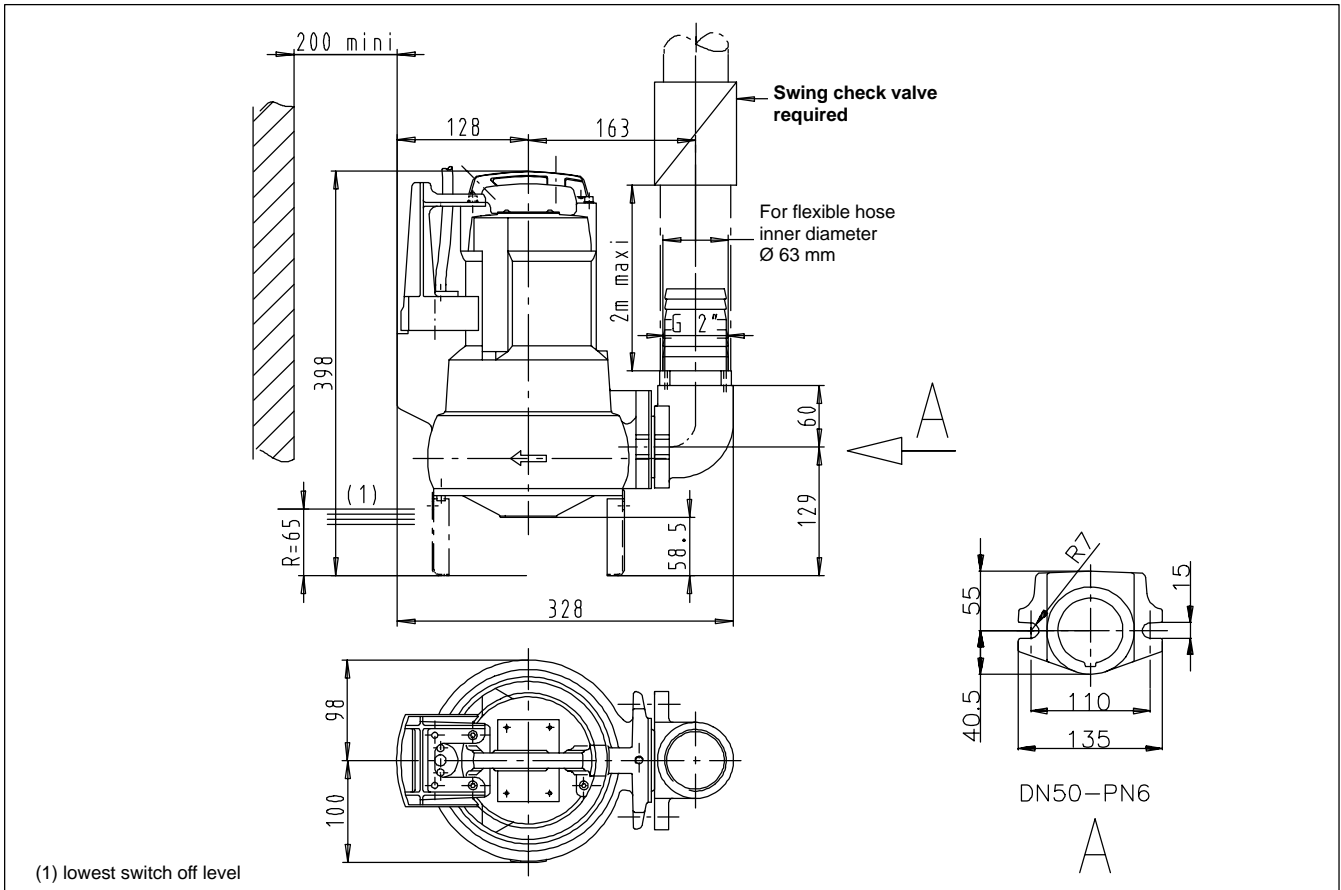

Ama[®]-Porter ICS[®] série 6 --

Transportable version

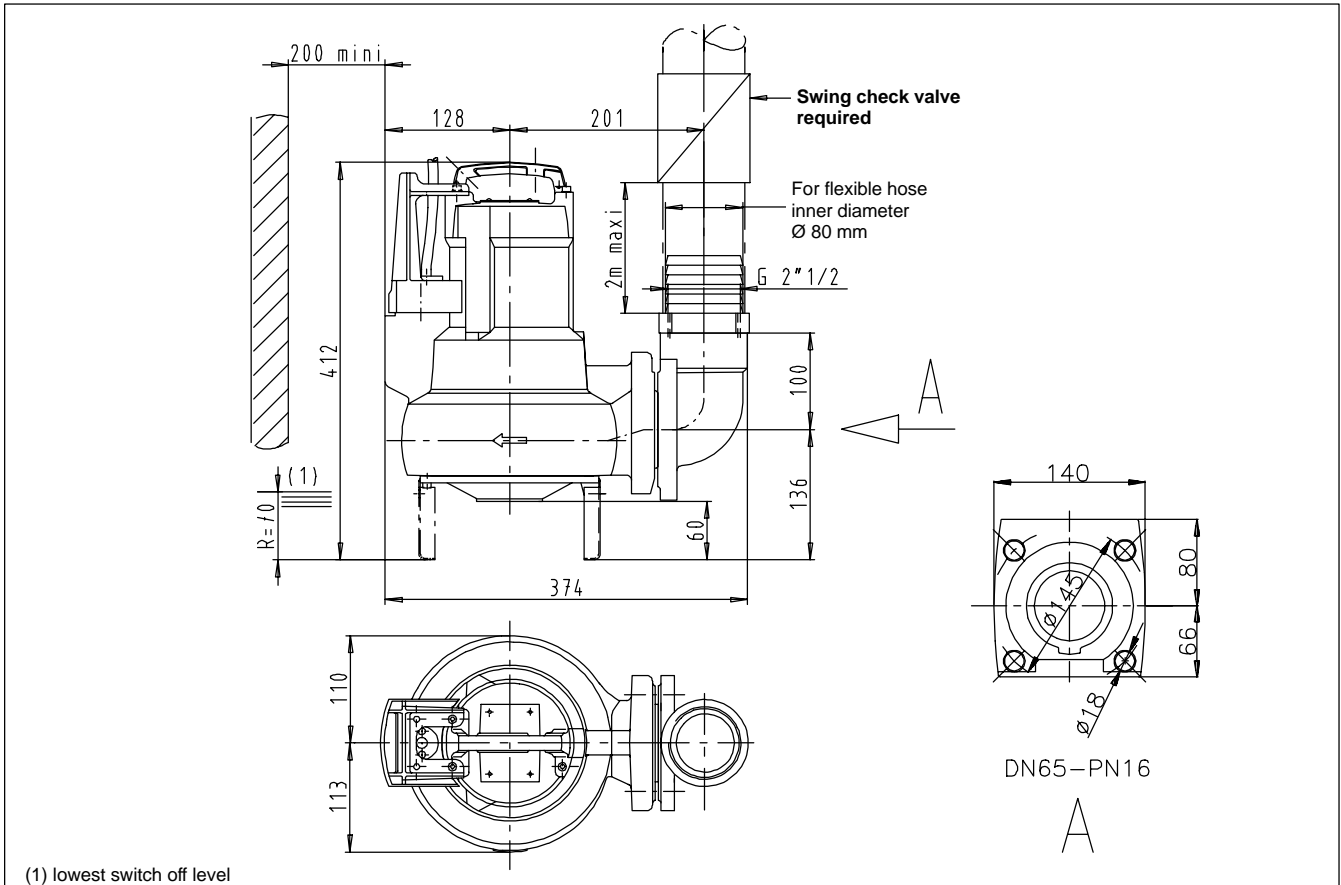

Dimensions

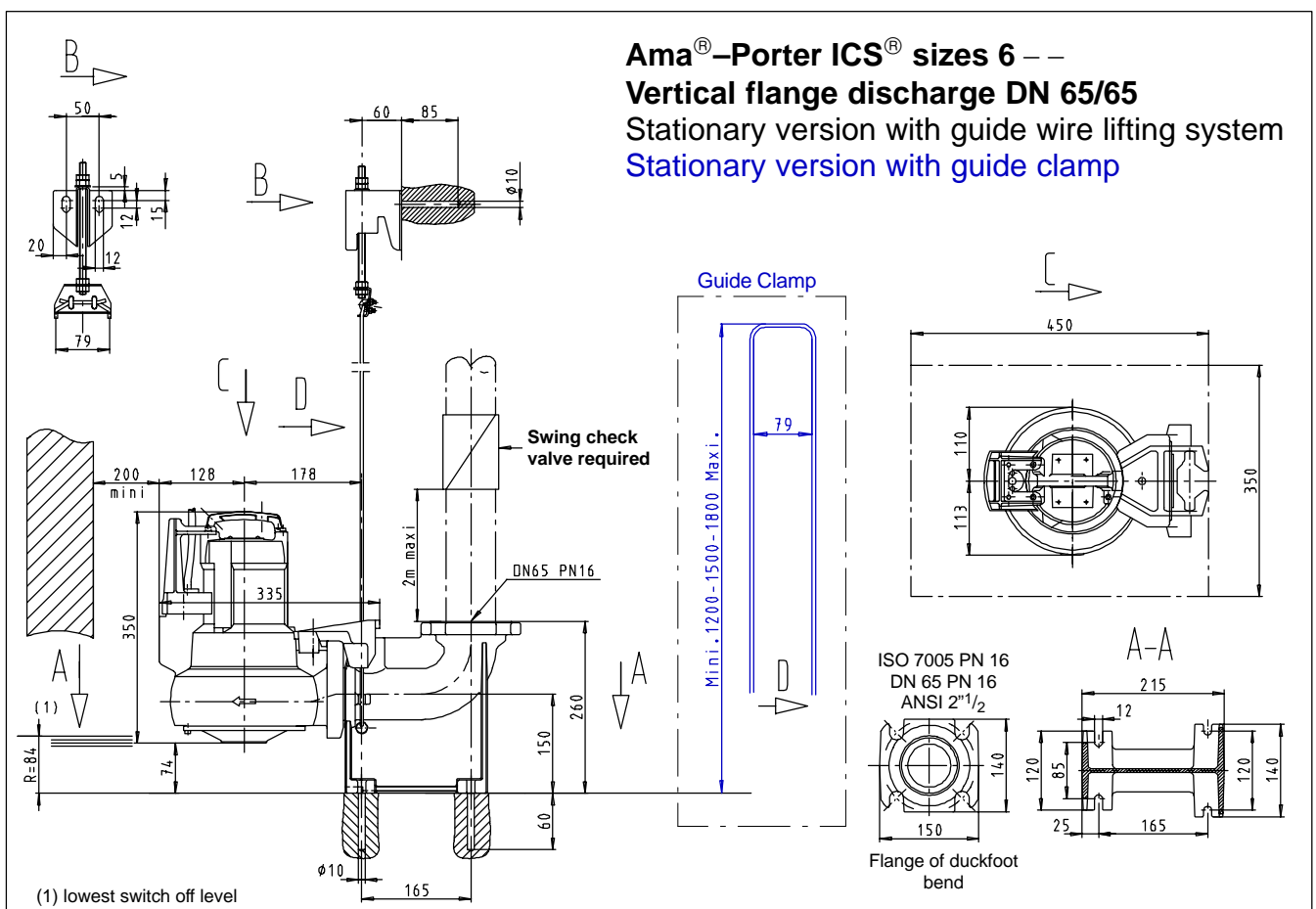
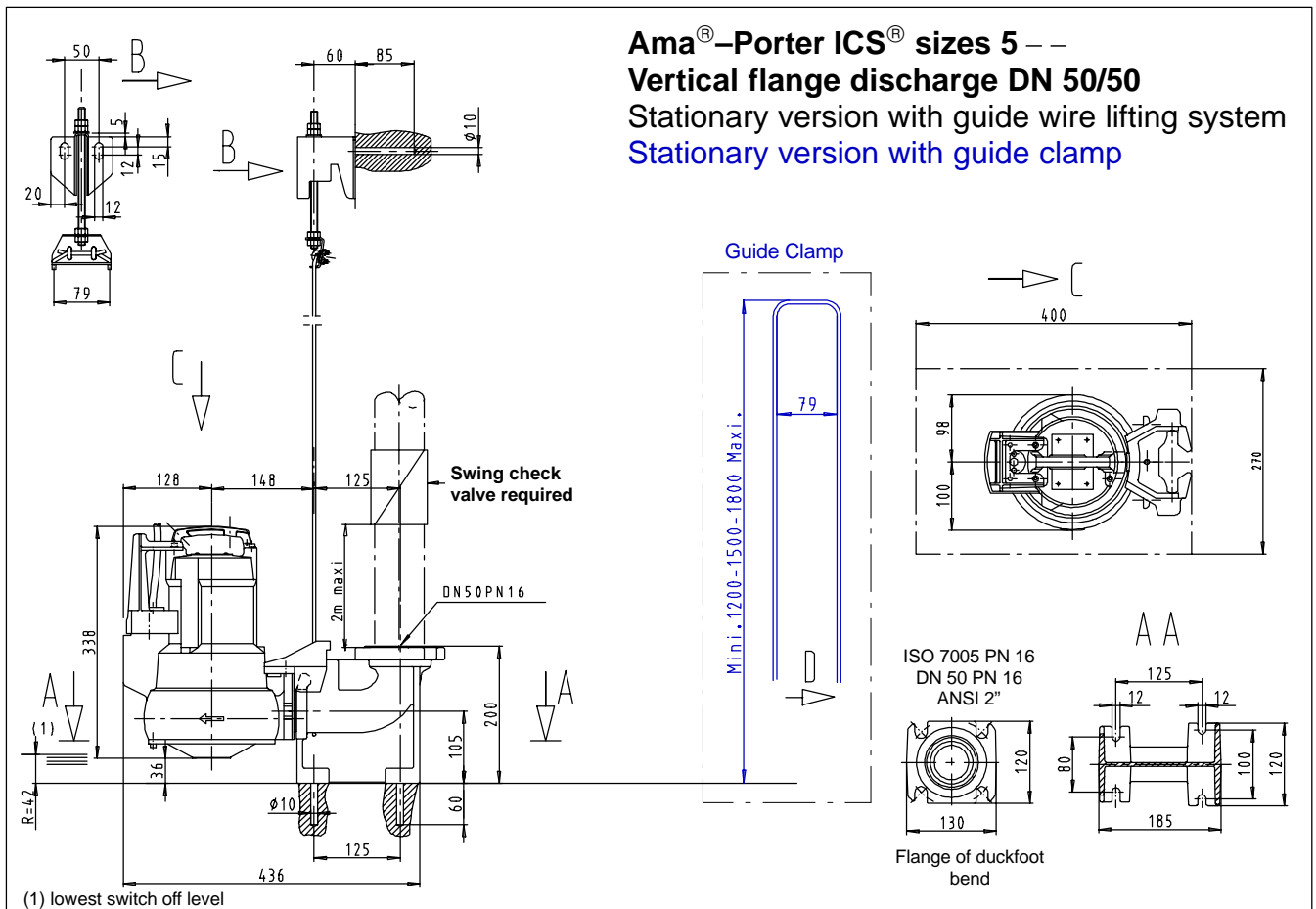

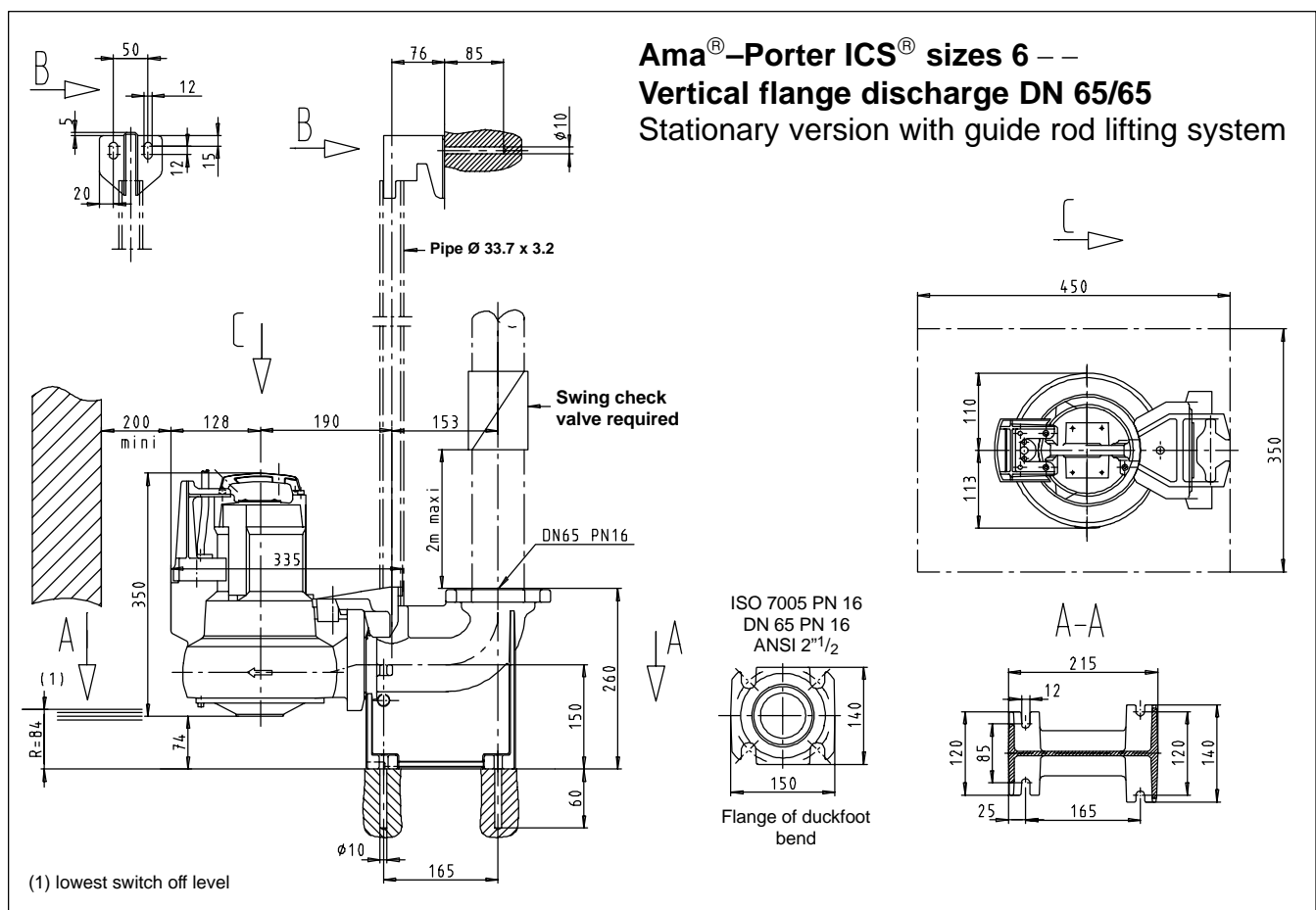
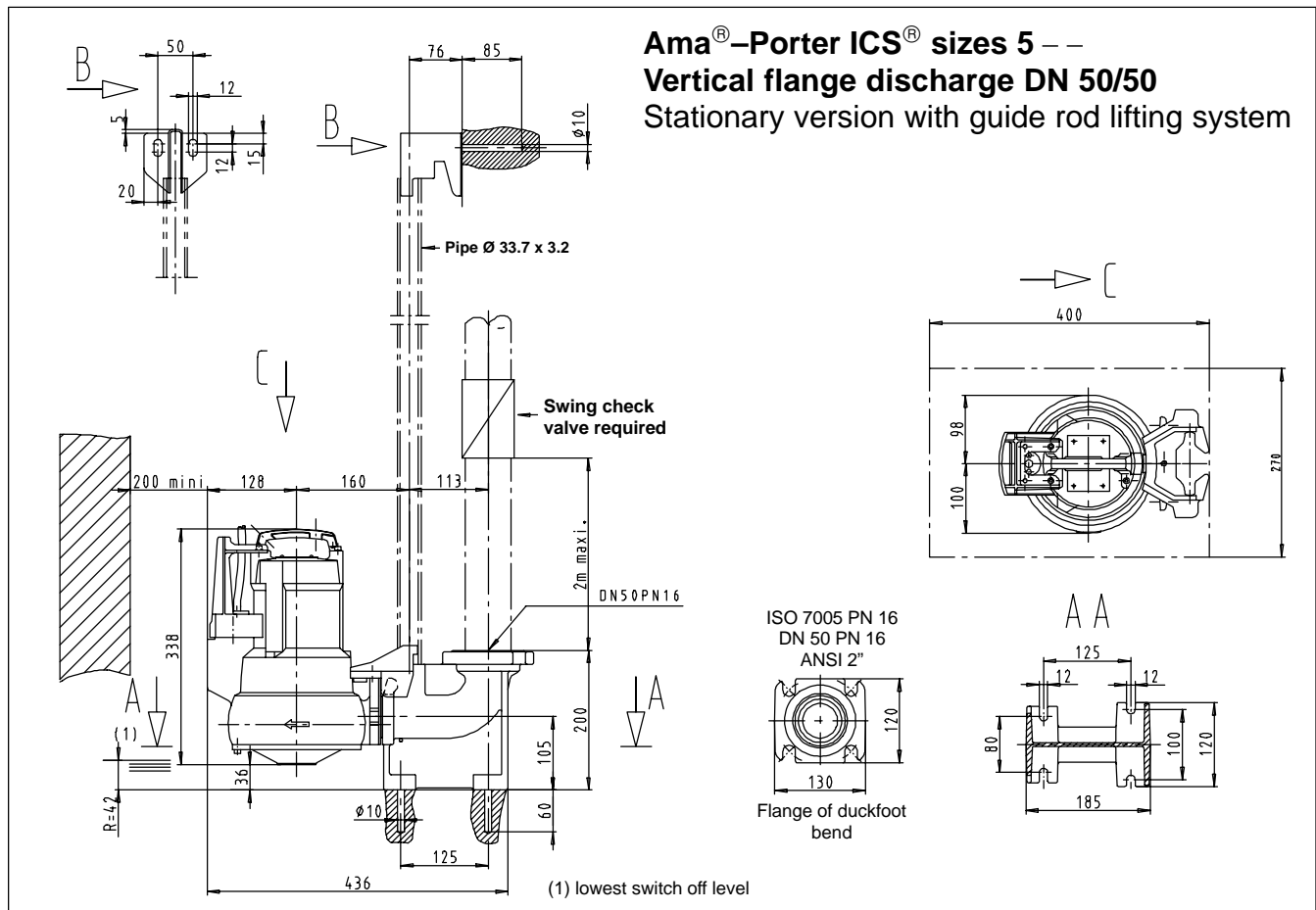
Dimensions

Dimensions

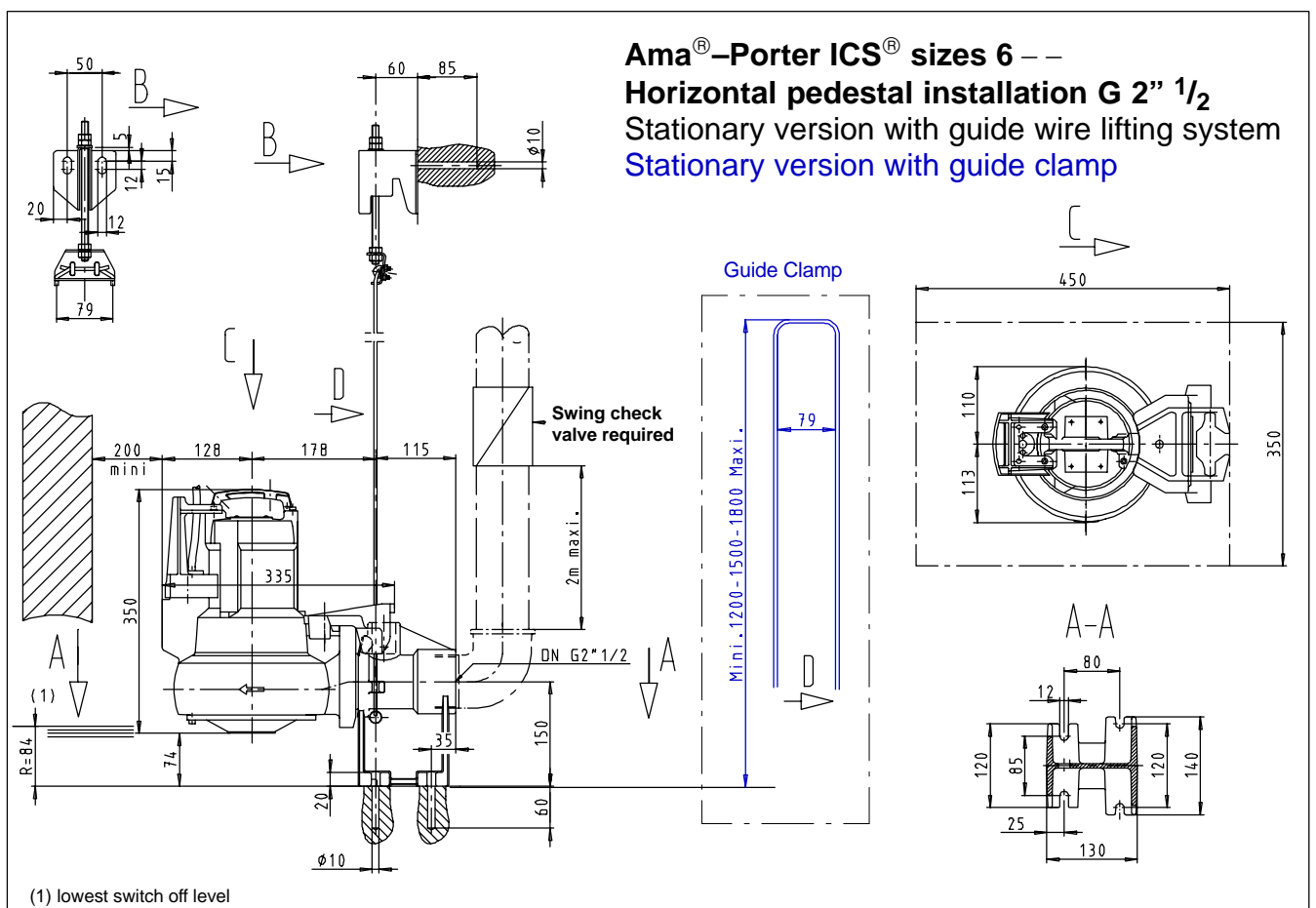
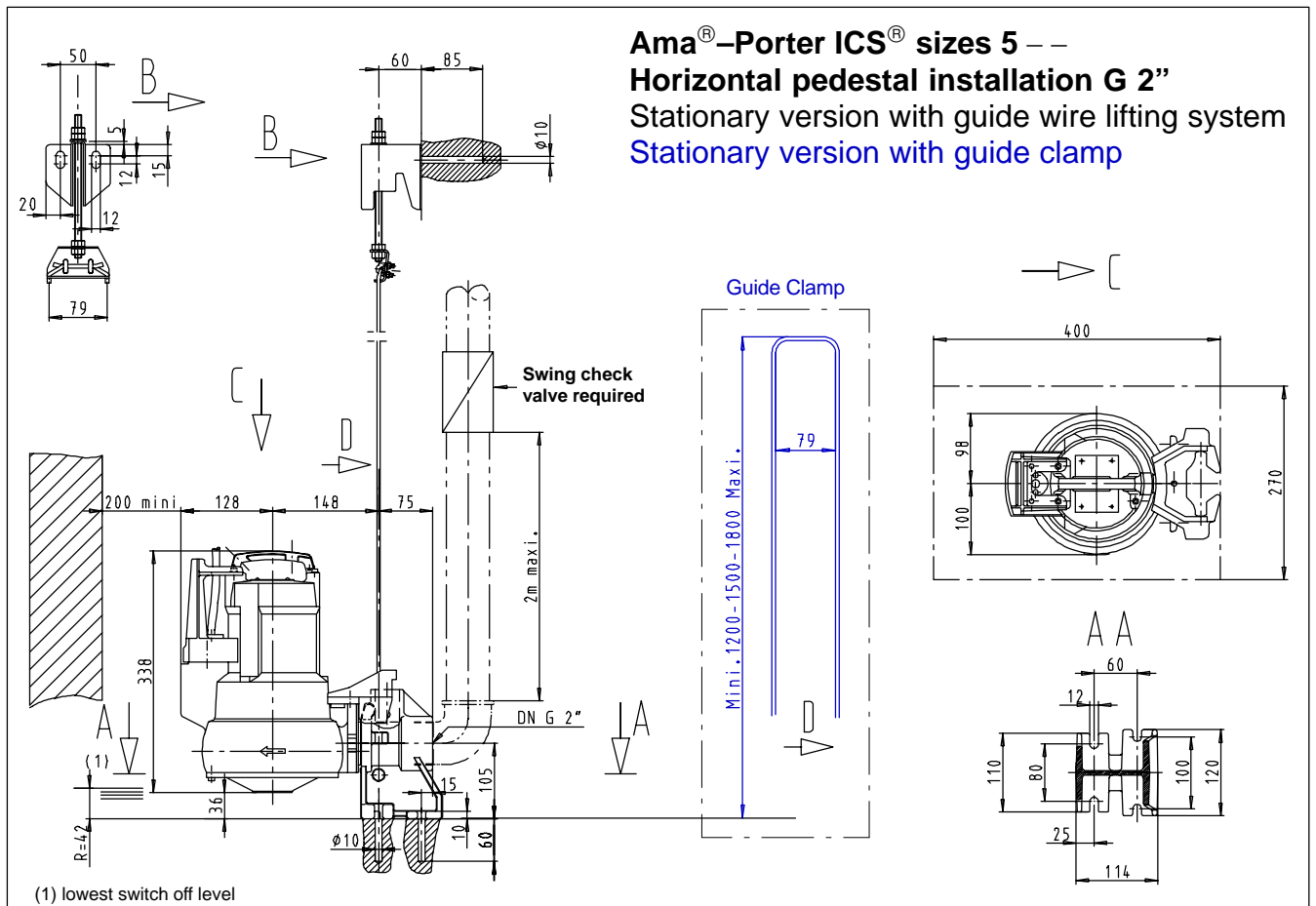

Dimensions

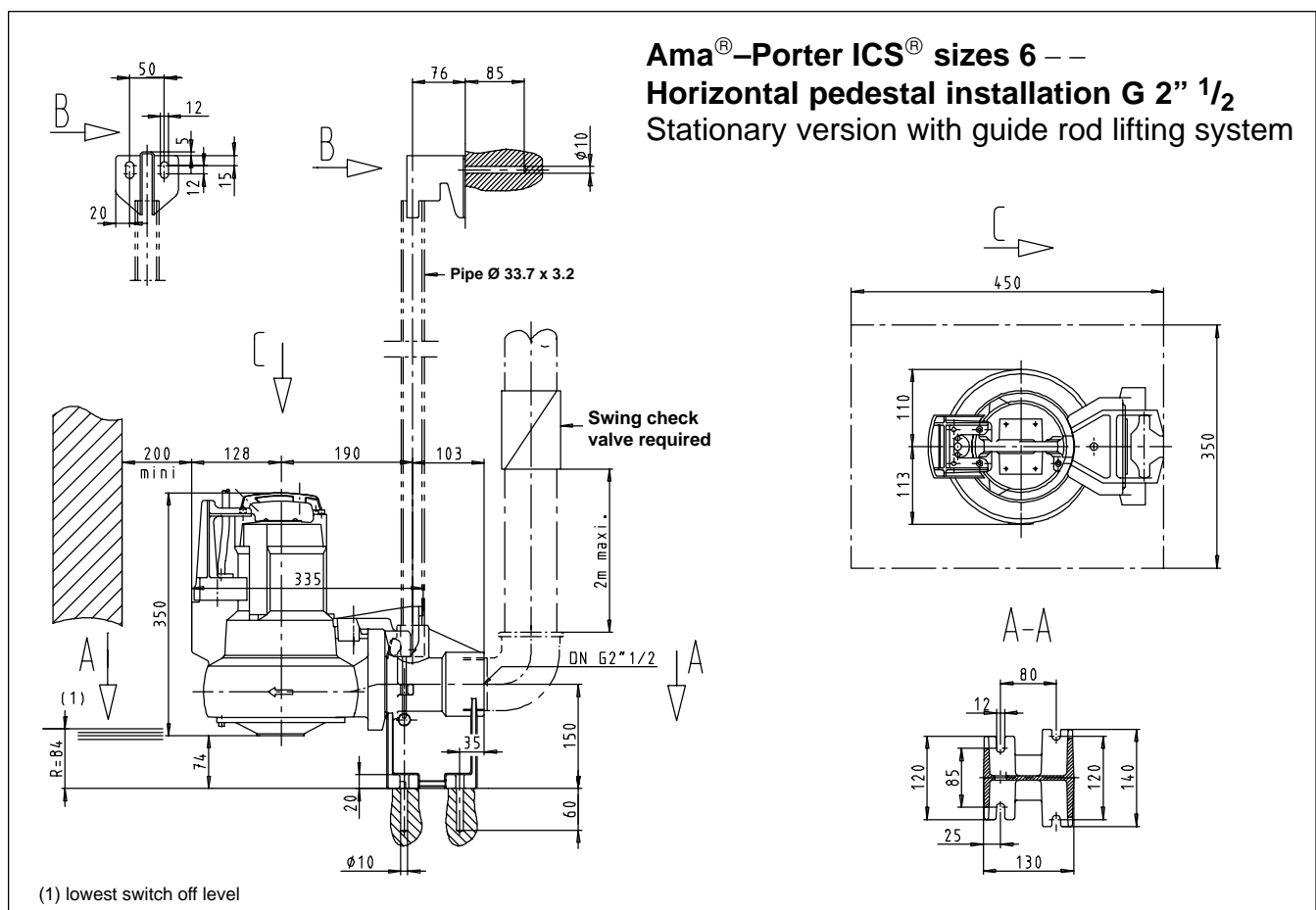
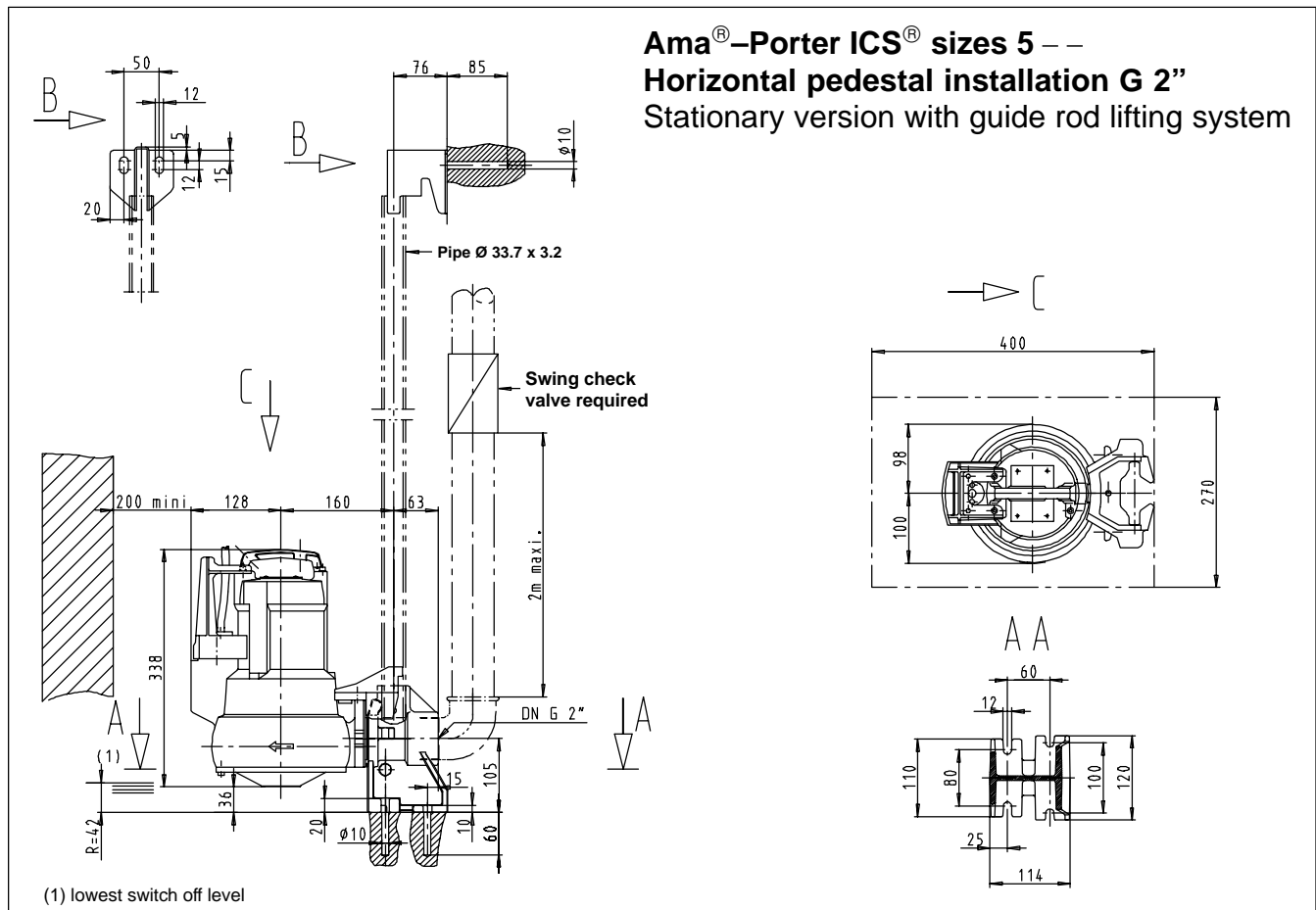

Installation in a sump
Recommended dimensions

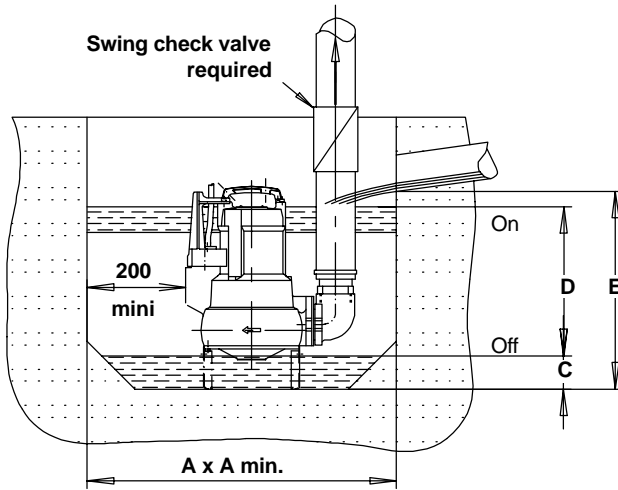

Single pumping station

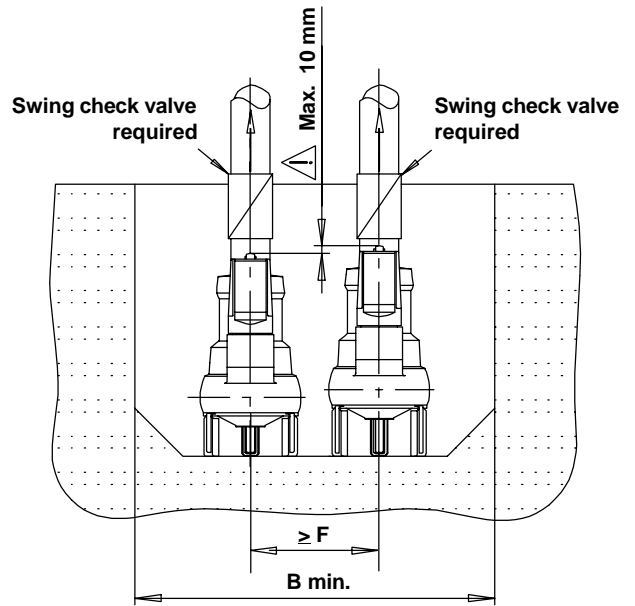





Dual pumping station

Dimensions in mm

	A x A	C	D	E
Ama-Porter 5 -- ICS	600 x 600	65	300	450
Ama-Porter 6 -- ICS	600 x 600	70	306	480

	A x B	C	D	E	F
Ama-Porter 5 -- ICS	600 x 750	65	300	450	300
Ama-Porter 6 -- ICS	600 x 750	70	306	480	350

Display Module (Option)

	<p>Display module for single-phase a.c.; operating status is not transmitted.</p> <p>Voltage 230 V, 1 phase + earthed conductor. Frequency 50/60 Hz, max. Current intensity 10 A. Temperature -10 °C to +50 °C. Type of enclosure IP 43. CEE plug and socket.</p> <p>Dimension : 105 x 60 x 90</p>	<p>Ident-N° 39 019 940</p> <p>Indicator lamps indicating:</p> <ul style="list-style-type: none"> - Full load white - Pump is available yellow - Pump is in operation green - Fault P1 red - Fault of partner orange
	<p>Display module for single-phase a.c.; operating status is transmitted</p> <p>Voltage 230 V, 1 phase + earthed conductor. Frequency 50/60 Hz. Max. current intensity 10 A. Temperature -10 °C to +50 °C. Type of enclosure: IP 54.</p> <p>Dimension : 166 x 90 x 56</p>	<p>Ident-N° 39 020 214</p> <p>Indicator lamps indicating:</p> <ul style="list-style-type: none"> - Full load white - Pump is available yellow - Pump is in operation green - Fault P1 red - Fault of partner orange - Reset orange
	<p>Display module for three-phase current; operating status is transmitted</p> <p>Voltage 400 V, 3 phases+earthed conductor. Frequency 50/60 Hz. Max. current intensity 5 A. Temperature -10 °C to +50 °C. Type of enclosure IP 54.</p> <p>Dimension : 166 x 90 x 56</p>	<p>Ident-N° 39 019 941</p> <p>Indicator lamps indicating:</p> <ul style="list-style-type: none"> - Full load white - Pump is available yellow - Pump is in operation green - Fault P1 red - Fault of partner orange - Reset orange
 <p>1~ 230 V</p>	<p>Display module for single-phase a.c.; with transmission of the operating status of 2 pumps</p> <p>Voltage 230 V, 1 phase + earthed conductor. Frequency 50/60 Hz, max. Current intensity 10 A per pump. Temperature -10 °C to +50 °C. Type of enclosure IP 54. 10A fuses integrated. On/Off switch.</p> <p>Dimensions : 185 x 147 x 77</p>	<p>Ident-N° 39 020 692</p> <p>Indicator lamps indicating:</p> <ul style="list-style-type: none"> - Full load white - Pump 1/pump 2 is available yellow - Pump 1/pump 2 is in operation green - Fault P1 red - Fault P2 red - Reset orange
 <p>3~ 400 V</p>	<p>Display module for three-phase current; with transmission of the operating status of 2 pumps</p> <p>Voltage 400 V, 3 phases + earthed conductor. Frequency 50/60 Hz. Max. current intensity 5 A per pump. Temperature -10 °C to +50 °C. Type of enclosure IP 54. 6A fuses integrated. On/Off switch.</p> <p>Dimensions : 185 x 147 x 77</p>	<p>Ident-N° 39 020 693</p> <p>Indicator lamps indicating:</p> <ul style="list-style-type: none"> - Full load white - Pump 1/pump 2 is available yellow - Pump 1/pump 2 is in operation green - Fault P1 red - Fault P2 red - Reset orange

An additional system must be provided to ensure overflow protection (e.g. AS 0 + float switch).

